



TOM

The new generation of PVC-O pipes



Excellence in high-pressure water piping

 **MOLECOR**
South East Asia

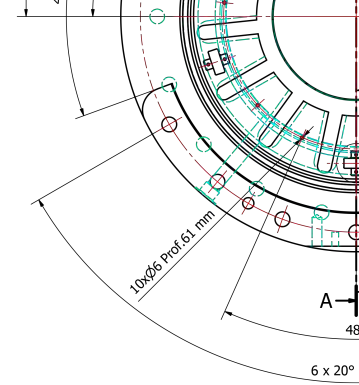

Molecular Orientation, a revolution in PVC

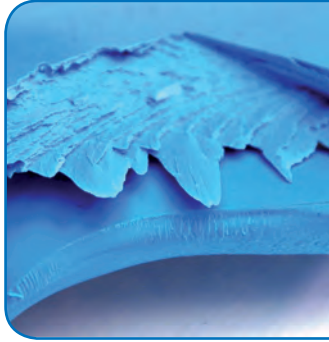

When PVC with its amorphous structure (lower section) is subjected to the orientation process, a laminate structure is obtained (upper section).

- ▶ **◎** TOM® PVC-O pipes are the most advanced pipes for the conveyance of high-pressure water currently available on the market, with a number of exceptional features for this kind of application, thanks to the process of Molecular Orientation.

PVC is essentially an amorphous polymer in which the molecules are located randomly. However, under certain conditions of pressure, temperature and speed, by stretching the material, it is possible to orient the polymer molecules in the same direction as which the material has been stretched.

Depending on the process parameters used and mostly stretch ratio, a higher or lower orientation degree will be obtained. The result is a plastic with a layered structure which layers can be seen at a glance.

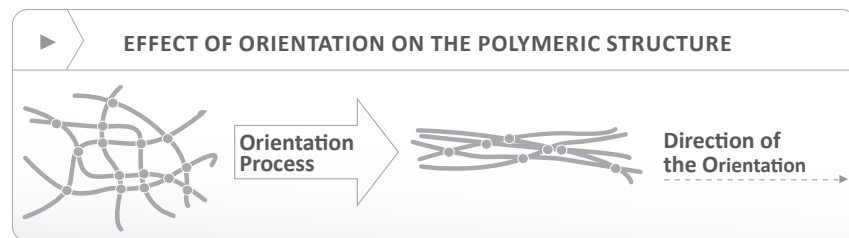

The Molecular Orientation process modifies the PVC's structure by giving the polymer's molecules a linear orientation.

A plastic with unbeatable properties

The process of Molecular Orientation greatly enhances PVC's physical and mechanical properties and gives it a number of exceptional features, without altering the advantages and properties of the original polymer. Thereby it is obtained a plastic with unbeatable qualities in terms of **resistance to traction and fatigue, flexibility and impact resistance.**

When used in high-pressure water pipelines **this type of piping has a high resistance and an extremely long lifetime.** Moreover, the pipe is highly energy-efficient and eco-friendly not only for the way it is made but also because of its subsequent use. Other advantages include reductions in costs and installation times.

For all these reasons, **TOM® PVC-O pipes are the best solution** for medium and high pressure water networks for irrigation systems, potable water supply, fire extinguishing networks and pumping systems, among other applications.



TOM® pipes

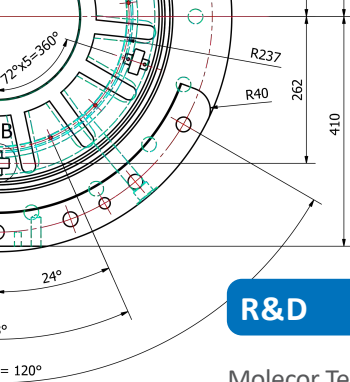

WHY MOLECOR IS DIFFERENT? ...



R&D

Molecor Tecnologia is a **company committed to research and development**, with clear **international vocation**, which markets products and technology developed entirely in Spain. **Molecor** firm commitment to **R&D**, goes beyond technology development and has been recognized with various **WIPO PCT** registered worldwide and with deals with the most reputable public research and development entities.

100% specialization

Molecor is dedicated exclusively to the development of the latest **technology applying Molecular Orientation** to PVC and to the implementation of **highly efficient solutions** for the conveyance of water under pressure. Throughout his trajectory **Molecor** has received several awards and recognitions that have contributed significantly to consolidate its presence and global leadership as a company dedicated to developing technology for the manufacture of **Oriented PVC pipes**.

Know How

The effort of the company in R&D as well as its exclusive dedication to PVC-O, have made the company **fully acquainted of the sector** thus being able to provide support in all phases of the manufacturing and installation processes of the product.

360° support:

- Certification & Standardization
- Promotion & Sales
- On-line and off-line supporting tools
- Full support during installation
- Industrial support

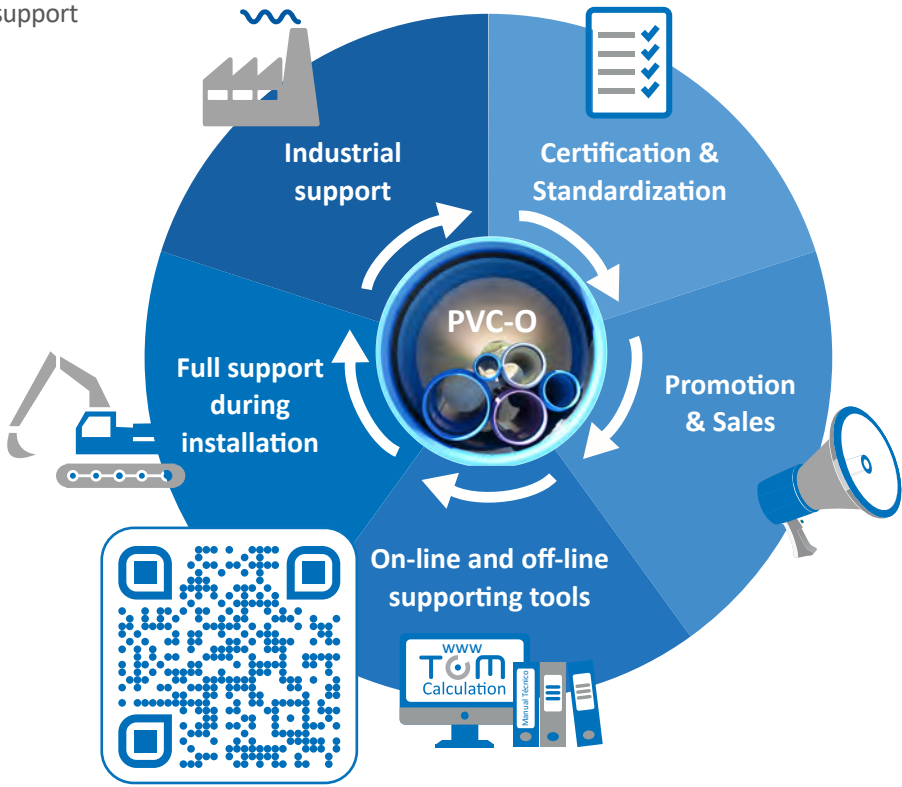

Cutting-edge technology for water



- ▶  TOM® PVC-O pipes have been developed by MOLECOR®, the only company in the world conceived and dedicated entirely to researching and manufacturing PVC-O pipes. Our manufacturing process is absolutely innovative and uses the most advanced and most reliable technologies currently available.

Up until now, although PVC-O pipes are recognized as providing the highest specifications, the technical limitations of the different manufacturing processes and the shortcomings of those processes in terms of efficiency were a barrier to the extensive use of this kind of pipes.

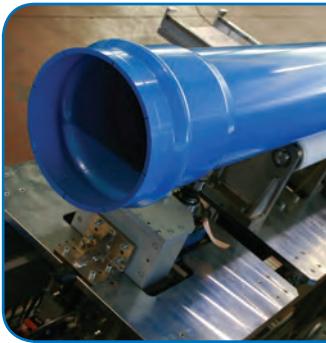

- ▶ The technology developed by MOLECOR® means that these limitations have now been overcome and it has also helped to make **considerable improvements** in TOM® pipes.

- Molecular Orientation is achieved by applying the precise and homogenous distribution of temperature and high pressures (up to 35 bars) thanks to **quality control checks** carried out on each individual pipe and throughout the entire manufacturing process.
- The TOM® pipes manufacturing process is continuous and fully-automated (as opposed to the traditional discontinuous method), providing **greater control over the end product and ensuring the uniform quality of each pipe**.

Manufacturing process developed by Molecor® uses most advanced technologies and it is completely automatized. This gives TOM® pipes maximum guarantee and quality.

Maximum Reliability and Security

- ▶ Thanks to the extraordinary technical advances of MOLECOR's manufacturing system, TOM® pipes offer the maximum reliability and security, as well as other **attractive advantages** over other products:



- **Maximum Molecular Orientation:** Class 500, according to the ISO 16422-2 and EN 17176-2 Standards, the highest orientation degree offering the best mechanical properties.
- **Greater reliability** of the end product.
- Strict dimensional tolerances.
- Homogeneous behavior of the materials used.
- Reinforced socket, shaped during the orientation process.

The most eco-friendly pipes with the environment

-  The environmental impact of a piping system depends on its composition and application thereof, being the type of raw material used, the production process, the finished product and the pipe's life expectancy, the main factors that determine the efficiency and sustainability throughout their life cycle.

TOM[®] PVC-O is the most environmentally friendly solution existing on the market, due to its best contribution to the correct sustainable development of the planet, as it has been demonstrated by different studies worldwide, since they present **environmental benefits at all stages of their life cycle**; thus resulting in **the most efficient from the energy point of view**.

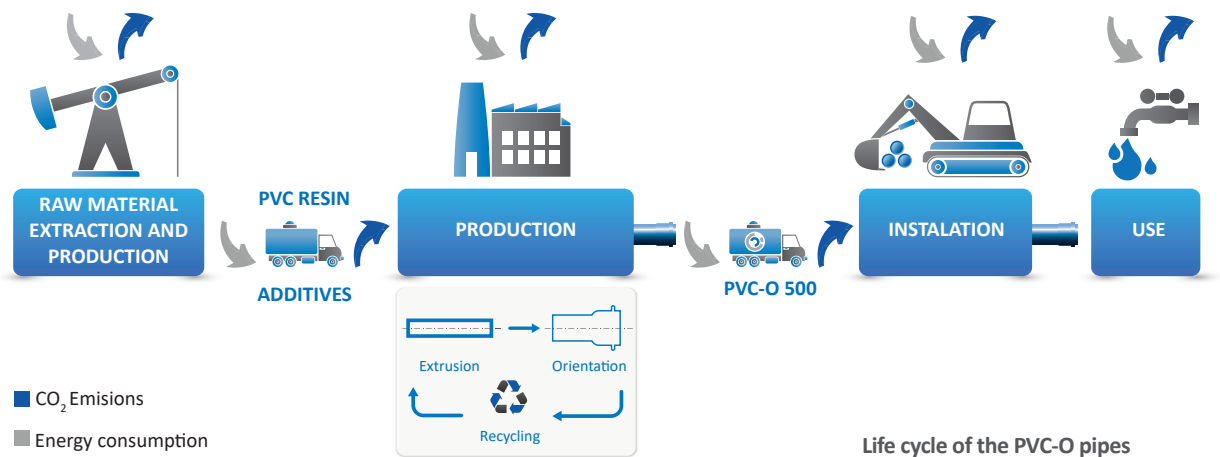

Resources efficiency

- The exceptional mechanical properties of these pipes allow **considerable savings in raw materials**. For the same external nominal diameter, TOM[®] requires less PVC.
- Only 43% of the PVC composition depends on petroleum. Therefore, the required consumption of this resource is lower than in other plastic solutions.
- **Energy consumption is lower in all phases of the life cycle**: raw material extraction, pipe manufacturing and use.

Throughout its lifetime, TOM[®] prevents unnecessary consumption of energy resources and **reduces CO₂ emissions into the atmosphere**.

Energy consumed by pipes (raw materials + manufacture) (kWh)

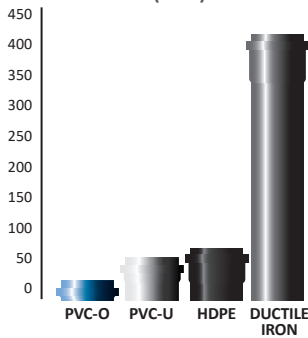

Energy consumed by raw materials (kWh)

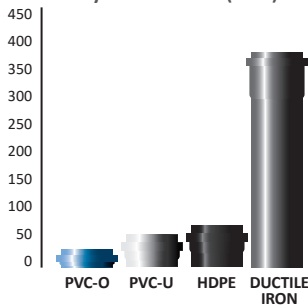

Energy consumed in manufacturing (kWh)

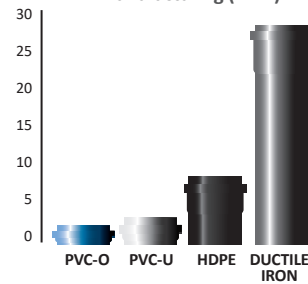

Energy consumed by pumping (kWh)

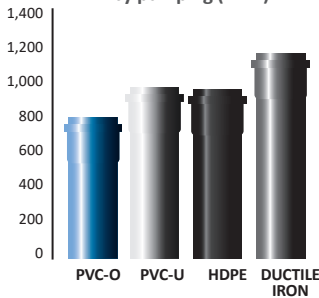

Estimated energy consumption by PVC-O, PVC-U, HDPE and Ductile Iron piping production and use. Polytechnic University of Catalonia, Spain, December 2005.

Optimal use of water resources

Thanks to their **long useful life and optimum water-tightness**, TOM® pipes are the best ally for the rational use of water resources.

Water supply networks installed with traditional materials are currently registering a leakage rate of up to 25% of channeled water and, the latter's chemical deterioration means that some water conduits are currently being replaced despite having been laid only a few years ago.

Water pipes must not only be resistant to pressure, must also carry the maximum amount of water **consuming the least quantity of energy**. The extreme smoothness of the inner wall of the TOM® pipe minimizes pressure loss, so the energy required for transport is lower.

Hydraulic capacity

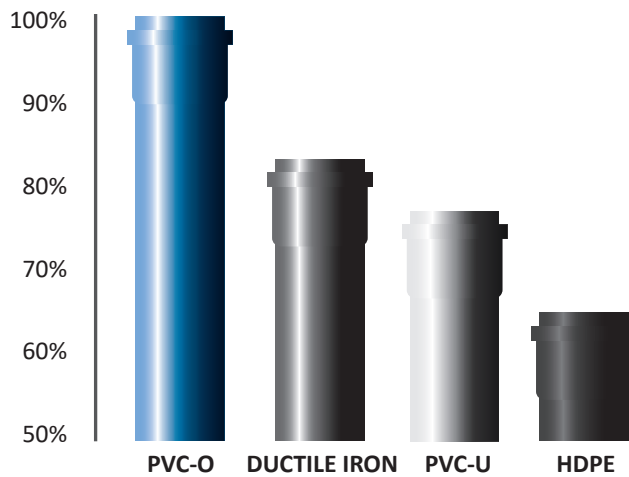

For a 1m DN250 mm PN16 bar

The infrastructures created with TOM® pipes are an **excellent tool for managing water resources for generations**.

Waste Management Efficiency



PVC is a **100% recyclable material**. Molecor, as part of the value chain of the plastics industry, shows its commitment to the environment by offering to the market products with a lower environmental impact, and incorporating the principles of the circular economy into their manufacturing.

Sustainability

🕒 TOM® and ecoFIT TOM® are **sustainable** products, in which design it has been taken into account the preservation of the environment considering aspects such as energy saving, sustainable use of natural resources, durability of the works and environmental friendliness of the materials used. For these reasons TOM® it is the only PVC-O pipe with the **MyHijau Mark Certificate** according to **ISO 14024 Type I ECO-Labels** and also has the **Sirim Eco-Label License 054 : 2016** to certify its commitment with sustainability.

Molecor has assessed the environmental impact of the TOM® pipes and ecoFIT TOM® fittings at all stages of their life cycle from cradle to grave, i.e. from the extraction of the raw material to the final disposal of the product, including the manufacture, distribution and use of the pipes. This life cycle analysis (LCA) has been carried out in accordance with the ISO 14040 and ISO 14044 standards.

Based on this analysis, the **Environmental Product Declaration (EPD)** has been prepared according to the requirements of EN ISO 14025 by applying the product category rules (PCR) for construction products indicated in EN 15804:2012 + A2: 2019 standard.



GlobalEPD EN15804-066
 Verified by AENOR
 Registered in the Global EPD program

An evaluation was made of the impact of the PVC-O pipe and fittings system on 16 environmental indicators, which are grouped according to the effect on the different environments:

Air and atmosphere

Global warming (climate change), ozone depletion, acidification and photochemical ozone formation.

Water

Freshwater eutrophication, marine eutrophication, water use and ecotoxicity in freshwater ecosystems.

Soil

Terrestrial eutrophication, fossil resource depletion potential, non-fossil resource depletion potential and soil quality potential index.

Human health

Human toxicity - carcinogenic effects, human toxicity - non-carcinogenic effects, particulate matter emission diseases and ionizing radiation HH.

TOM® & ecoFIT TOM® PVC-O Declared unit: 1 kilogram		
Parameter	Unit	Total
GWP - total: Global warming potential	kg CO ₂ eq	1.77E+01
ODP: Stratospheric ozone depletion potential	kg CFC-11 eq	1.11E-06
AP: Acidification potential, cumulative surplus;	mol H+ eq	6.27E-02
EP-freshwater: Fraction of nutrients reaching the final freshwater compartment	kg P eq	9.46E-05
EP-marine: Fraction of nutrients reaching the final marine water compartment	kg N eq	2.46E-02
EP-terrestrial: Eutrophication potential, cumulative surplus	mol N eq	2.63E-01
POCP: Tropospheric ozone formation potential	kg NMVOC eq	9.30E-02
ADP-minerals & metals: Abiotic resource depletion potential for non-fossil resources	kg Sb eq	2.34E-06
APD-fossil: Abiotic resource depletion potential for fossil resources	MJ, v.c.n.	2.47E+02
WDP: Water deprivation potential (user), weighted water deprivation consumption	m ³ eq	4.77E+00
PM: Potential for disease incidence due to emissions of particulate matter	Incidence of diseases	1.54E-06
IRP: Exposure efficiency of human potential relative to U235	kBq U235 eq	1.88E-01
ETP-fw: Comparative ecosystem toxic unit potential - freshwater	CTUe	1.05E+02
HTP-c: Comparative ecosystem toxic unit potential - carcinogenic effects	CTUh	1.76E-09
HTP-nc: Comparative ecosystem toxic unit potential - non-carcinogenic effects	CTUh	1.15E-07
SQP: Soil quality potential index	Pt	3.29E+00

Environmental impacts of TOM® and ecoFIT TOM® in cradle-to-grave LCA. Stages : A1-A2-A3-A4-A4-A5-C1-C2-C3-C3-C4-D

The best known environmental parameter is the **Carbon Footprint**, which takes into account the greenhouse gas emissions into the atmosphere expressed as CO₂, and corresponds to the result of the environmental indicator of climate change.

TOM®: The best choice for high-pressure fluid transport



The impact of a 500 kg rock dropped from a height of 3 metres leaves a TOM® pipe completely unscathed.

Unbeatable impact resistance

- TOM® pipes have a **high resistance to shock**. This means that there are minimized breakages during installation or during on-site trials caused by dropping or by impacts from stones.

Furthermore, Molecular Orientation prevents the propagation of cracks and scratches and eliminates the risk of rapid crack behaviour. The result is a spectacular increase in the product's useful life.

High short- and long-term hydrostatic resistance

- TOM® pipes offer a resistance to internal pressure of up to **two times the nominal pressure** (32 bar in PN16 bar pipes or 400 psi in PN200 psi), which means that they can bear sporadic excessive pressure such as water hammers and other malfunctions in the network.

Moreover, the material creep behavior is very low, ensuring the durability of the pipe working at nominal pressure for over a hundred years.

Excellent response to water hammers

- TOM® pipes offer lower celerity than other piping systems (four times less than ductile iron pipes), which means less water hammers caused by sudden variations in water volume and pressure. This reduces and almost **eliminates the possibility of breakage** during opening and closing in the water network and when pumping gets under way, protecting every component of the network.

Increased hydraulic capacity

- Molecular Orientation widens the inner section of the pipe, giving TOM® pipes a **higher internal diameter and greater flow section**. Also, the internal surface is extremely smooth, reducing load loss and making it more difficult for deposits to be formed on the inner walls.

As a result, TOM® pipes offer between **15% - 40% more hydraulic capacity** than pipes made from other materials and with the same external dimensions.

Maximum flexibility

- Thanks to their excellent elasticity, TOM® pipes can bear **big deformations of their internal diameter**. When crushed, or in the event of a mechanical accident, TOM® pipes immediately go back to its original shape, thus minimizing the risk of potential breakage by soil subsidence or sharp edges on rocks or machinery, for example. And thanks to their considerable capacity for bearing heavy loads, TOM® pipes ensure **optimum performance once laid underground**.



Completely corrosion-resistant

- Oriented PVC is immune to corrosion and to natural chemical substances, as well as to aggression from micro- and macro-organisms. **TOM® pipes, therefore, are not degradable**. Moreover, they do not require any type of special protection or coating, which means cost-savings.



TOM® pipes will take any kind of deformation without suffering structural damage.

Total water quality

- The quality of the fluid that circulates in TOM® pipes will **always remain unaltered**, given that the material neither suffers corrosion nor migrations within the pipes or in their coating. Mandatory tests such as those made according to the Malaysian law MS 1583 in line with the health regulations in force in Malaysia, show that the excellent qualities of these pipes comply with the required health standards for **water for human consumption**.

TOM® pipes also comply with other sanitary certifications that demonstrate its suitability for being used with water for human consumption, such as the law RD 140/2003, ACS, WRAS or DWI, certifications in accordance with the health legislation in force in Spain, France and the United Kingdom respectively.

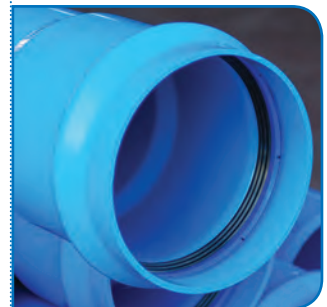

Locked-in ring seals ensure a perfect water-tight fit.

Completely water-tight

- Joints are 100 percent watertight and are guaranteed not to displace once the pipes have been installed. TOM® pipes are **easy to join** and can be installed by lower-qualified workers.

Lower cost and easier installation

- TOM® PVC-O pipes are **lighter and easier to handle** than other pipes made from other materials: in most cases, handling does not require machinery. Beside this, due to the easiness of their union, flexibility and impact resistance these pipes allow higher **cost effectiveness, performance and installation speed in comparison with pipes of other materials**.



TOM® pipes are extremely lightweight.

The best mechanical properties

Tensile resistance

The PVC-O stress strain curve changes significantly compared to conventional plastics behaviour, coming very close to the metal ones.

Mechanical properties complete transformation of PVC-O compared to conventional PVC can only be achieved in the higher class PVC-O Class 500, such as TOM® pipes.

STRESS-STRAIN BEHAVIOUR

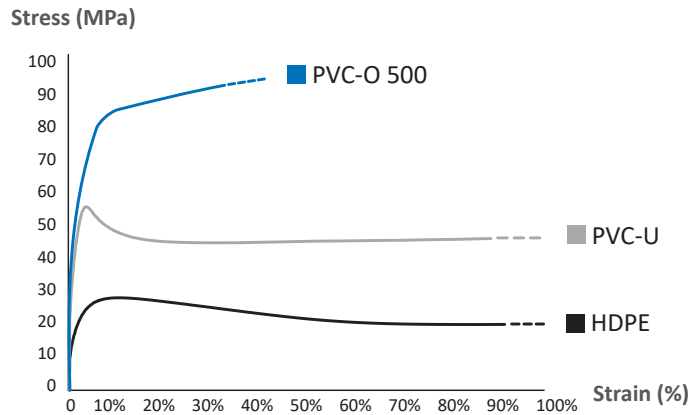

* Circumferential tension values

Long-term hydrostatic resistance

Materials lose their mechanical properties when subjected to strain for a long period of time. This characteristic, known as creep, appears to a far lesser extent in PVC-O 500 than in conventional plastics, which means better properties over the long term. Bearing in mind that PVC-O is exceptionally resistant to fatigue and has a very good chemical resistance, in common with conventional PVC.

TOM® pipe maintains the characteristics of a class 500 pipe over **100 years** as indicated by long-term tests (10,000 hours) carried out by an independent accredited laboratory to pipe according to the **ISO 9080: and UNE – EN ISO 1167 Part 1 and 2** standards. This means that the pipe can withstand its nominal pressure beyond 100 years, as long as there are no alterations in the operation of the installation. Molecor TOM® pipe has a useful life of more than **100 years**.

STRESS REGRESSION LINE

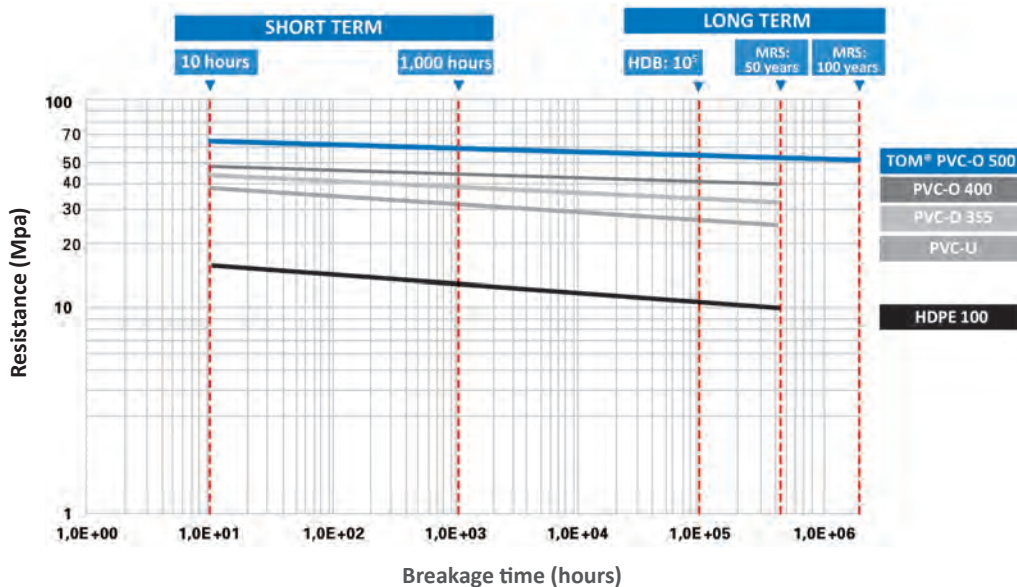

Piping and material mechanical properties

- The following table summarizes the technical characteristics of TOM® PVC-O pipes in comparison with other plastic pipes.

Product Standard	Units	TOM® PVC-O 500	PVC	HDPE-100	HDPE-80
		ISO 16422 UNE-EN 17176	UNE-EN ISO 1452	UNE-EN 12201	UNE-EN 12201
Minimum required strength (MRS)	MPa	50.0	25.0	10.0	8.0
Overall service coefficient (C)	-	1.4	2.0 ⁽¹⁾	1.25	1.25
Design stress (σ)	MPa	36.0	12.5	8.0	6.3
Short term elasticity modulus (E)	MPa	4,000	>3,000	1,100	900
Resistance to uniaxial traction	MPa	≥48	≥45	19	19
Resistance to hoop traction	MPa	>85	≥45	19	19
Shore hardness D at 20 °C	-	81 - 85	70 - 85	60	65

(1) For pipes with a DN ≥110.

Other material characteristic

- The table below shows other, non-mechanical characteristics of PVC-O 500.

Characteristic	Units	Value
Density	kg/dm ³	1.35 - 1.46 ⁽¹⁾
PVC Resin K value	-	>64
Poisson coefficient	-	0.4
Vicat temperature	°C	≥80
Lineal expansion coefficient	°C ⁻¹	7·10 ⁻⁵
Thermal conductivity	Kcal/mh°C	0.14 - 0.18
Specific heat at 20 °C	cal/g°C	0.20 - 0.28
Dielectric stiffness	kV/mm	20 - 40
Dielectric constant at 60 Hz	-	3.2 - 3.6
Transverse resistivity at 20 °C	Ω/cm	>10 ¹⁶
Absolute roughness (ka)	mm	0.001
Absolute roughness (Hazen Williams)	m ^{0.37} /s	155
Manning roughness coefficient (n)	m ^{-1/3} s	0.0074

(1) Although the standard allowance includes this range. TOM® PVC-O pipe is between 1.37 and 1.43 kg/dm³.

Characteristics of the water-tight joint

Characteristic	Units	Value
Elastomer hardness	IRHD	60 ±5

Unbeatable Hydraulic Properties

Hydraulic capacity

Water pipes requirements are not only related to pressure resistance; they also have to **transport the highest amount of water while consuming the least energy**. TOM® pipes walls are thinner than conventional plastic ones and are on their inside smoother than metals, which means that a greater hydraulic capacity is attained.

Comparison of hydraulic capacity: TOM® PVC-O PN16 pipes vs other materials (constant load loss)

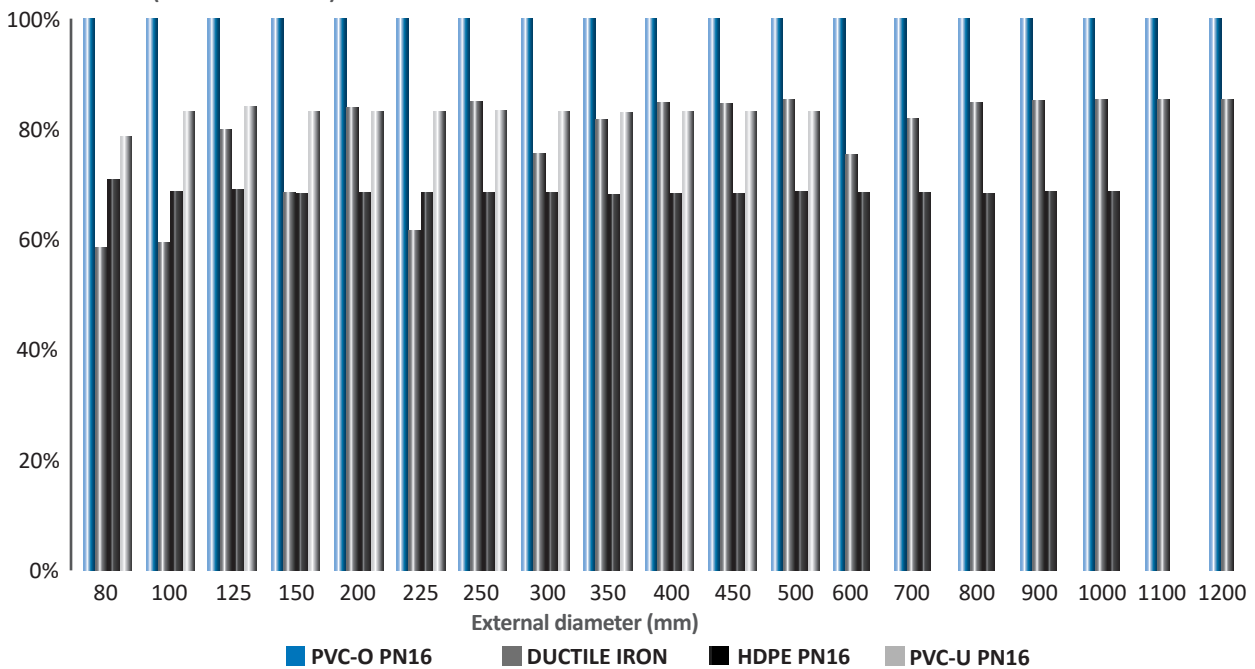

Using pipes with a lower hydraulic capacity involves necessarily using a larger nominal diameter, which has a negative effect on both profitability and infrastructure investment costs. **Using TOM® means you get more hydraulic capacity from your investment costs.**

Hydraulic capacity/Piping costs compared to TOM® PVC-O PN16

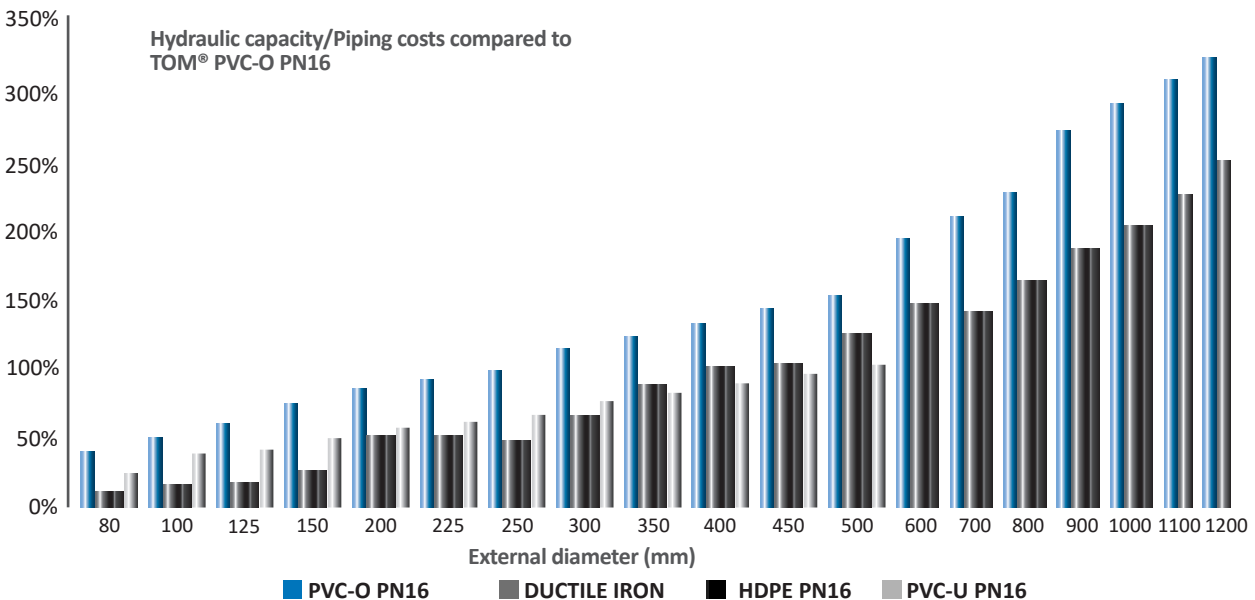

Water Hammer

- Water hammers occur when liquid flowing through piping stops suddenly when a valve is opened or closed, if a pump is stopped or started or by airlocks shifting within the pipe. Water hammers can result in an **higher overpressure than the pipe’s working pressure and lead it to breakage**, specially when the pipe has already been damaged by impacts or corrosion.

Water hammers (P) depend on the celerity (a), which is the wave speed, and the fluid’s change of speed (V). The celerity depends basically on the pipe’s dimensions (the relationship between the external diameter and the minimum thickness) and the specifications of the material with which the tube is made (Young’s modulus, E).

$$P = \frac{a \cdot V}{g} ; \quad a = \frac{9900}{\sqrt{48.3 + K_c \cdot \frac{D_m}{e}}} ; \quad K_c = \frac{10^{10}}{E}$$

a: acceleration (wave propagation speed), in m/s

D_m: average pipe diameter, in mm

e: pipe thickness, in mm

K_c: function coefficient of the modulus of elasticity (E) of the material of the pipe expressed in kg/m²

E: modulus of elasticity, in kg/m² for the TOM® PVC-O pipe: 4x10⁸ kg/m²

TOM®’s PVC-O pipes have a significantly lower celerity than pipes made from other materials, particularly so with metal piping. It is particularly significant the difference with pipes made of metal materials, in which the water hammers effects can be very high.

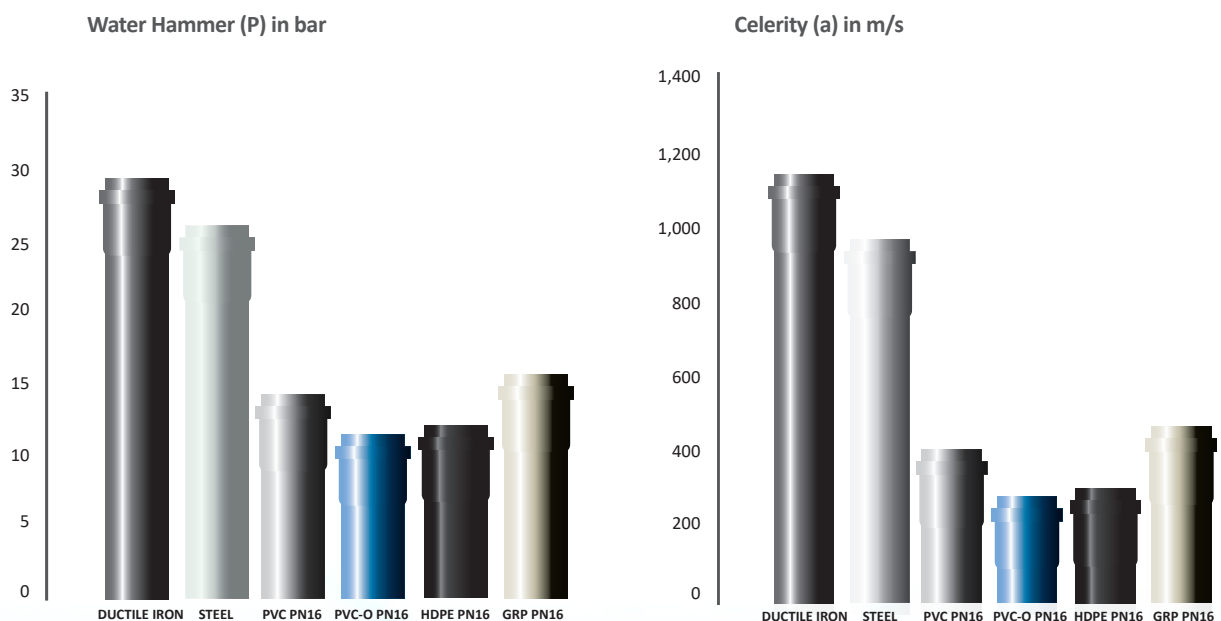

Overpressure produced by sudden pipe shut down with water flowing at 2.5 m/s.

A range for all kinds of applications

- TOM® offers a broad range of piping covering all medium- and high-pressure needs.

Applicable Laws and Standards

TOM® PVC-O pipes are manufactured in accordance with:

- **International Standard ISO 16422**, applied to “Pipes and joints made of oriented unplasticized poly(vinyl chloride) (PVC-O) for the conveyance of water under pressure” Part 1: General, Part 2: Pipes and Part 5: Fitness for purpose of the system.
- **SNI-ISO 16422** “Pipa dan sambungan dibuat dari polivinil klorida non plastisasi terorientasi (PVC-O) untuk mengalirkan air bertekanan - Spesifikasi / Pipes and joints made of oriented unplasticized poly(vinyl chloride) (PVC-O) for the conveyance of water under pressure - Specifications”
- **UNE-EN 17176** standard, applied to “Plastic piping systems for water supply and for buried and above ground drainage, sewerage and irrigation under pressure- Oriented unplasticized poly(vinyl chloride) (PVC-O). Part 1: General, Part 2: Pipes and Part 5: Fitness for purpose of the system” (based on **European Standard EN 17176**)

Other international standards applicable to PVC-O are as follows. Molecor® could manufacture pipes according to these standards under request.

- USA: ASTM F1483 “Standard Specification for Oriented Poly(Vinyl Chloride), PVCO, Pressure Pipe”; and ANSI/AWWA C909 “Molecularly Oriented Polyvinyl Chloride (PVCO) Pressure Pipe”.
- Australia: AS/NZS 4441 “Oriented PVC (PVC-O) pipes for pressure applications”.
- India: IS 16647 “Oriented Unplasticized Polyvinyl Chloride (PVC-O) Pipes for Water Supply – Specification”.
- Canada: CAN/CSA-B137.3.1 “Molecularly oriented polyvinylchloride (PVCO) pipe for pressure applications”.

Material classification

ISO 16422 and **UNE-EN 17176-2** standards cover several types of PVC-O material, classified according to their MRS (Minimum Required Strength), because Molecular Orientation can be achieved to a greater or lesser extent through different manufacturing processes. **TOM® PVC-O pipe is manufactured only in the highest class (PVC-O 500)**, which offers the highest degree of orientation and thus ensures the best mechanical performance. Subsequently, TOM® pipes **present higher advantages** compared to other materials.

	TOM® PVC-O 500 Pipe			
	PN12.5	PN16	PN20	PN25
Material class	500	500	500	500
MRS (Mpa)	50.0	50.0	50.0	50.0
Nominal pressure (bar)	12.5	16.0	20.0	25.0
Burst pressure over 50 years (bar) ⁽¹⁾	17.5	22.4	28.0	35.0
Burst pressure over 10 hours (bar) ⁽¹⁾	23.1	28.9	36.7	48.1
Maximum trial pressure onsite (bar) ⁽²⁾	17.5	21.0	25.0	30.0
Circumferential stiffness (kN/m ²) ⁽³⁾	5	7	11	20
Colour ⁽⁴⁾	blue/purple	blue/purple	blue/purple	blue/purple

(1) With a temperature of 20° C.

(2) According to EN 805:2000 standard with estimated water hammer.

(3) Average stiffness per pipe according to established tolerances.

(4) Available in blue (supply) and purple (reuse). For other colours, please contact us.

Dimensions

TOM® PVC-O 500 Pipe										
Nominal Pressure (bar)	PN12.5			PN16*			PN20		PN25*	
Nominal Diameter (DN)	Outside Diameter (OD)		Inside Diameter (ID)	Wall Thickness C1.4 (e)	Inside Diameter (ID)	Wall Thickness C1.4 (e)	Inside Diameter (ID)	Wall Thickness C1.4 (e)	Inside Diameter (ID)	Wall Thickness C1.4 (e)
	min.	max.	average	min.	average	min.	average	min.	average	min.
mm	mm	mm	mm	mm	mm	mm	mm	mm	mm	mm
90*	90.0	90.3	84.8	1.6	84.3	2.0	84.3	2.5	83.0	3.1
110*	110.0	110.4	103.6	2.0	103.1	2.4	103.0	3.1	100.8	3.8
125*	125.0	125.4	117.8	2.2	117.8	2.8	117.1	3.5	114.5	4.3
140*	140.0	140.5	132.3	2.5	132.3	3.1	131.1	3.9	128.3	4.8
160*	160.0	160.5	152.1	2.8	151.2	3.5	149.8	4.4	146.6	5.5
200*	200.0	200.6	190.1	3.5	189.0	4.4	187.3	5.5	183.3	6.9
225*	225.0	225.7	213.9	4.0	212.6	5.0	210.7	6.2	206.2	7.7
250*	250.0	250.8	237.6	4.4	236.3	5.5	234.1	6.9	229.1	8.6
315*	315.0	316.0	299.4	5.5	297.7	6.9	295.0	8.7	288.6	10.8
355*	355.0	356.1	337.4	6.2	335.5	7.8	332.5	9.8	325.3	12.2
400*	400.0	401.2	380.2	7.0	378.0	8.8	374.6	11.0	366.5	13.7
450*	450.0	451.4	427.7	7.9	425.3	9.9	421.4	12.4	412.3	15.4
500*	500.0	501.5	475.2	8.8	472.5	11.0	468.2	13.7	458.1	17.1
630	630.0	631.9	598.8	11.0	595.4	13.8	590.0	17.3	577.2	21.6
710	710.0	712.0	674.8	12.4	671.0	15.4	664.9	19.2	654.7	24.4
800	800.0	802.0	760.4	14.0	756.1	17.4	749.2	21.6	733.0	27.4
900	900.0	902.7	855.4	15.7	850.6	19.6	839.5	24.3	824.1	30.9
1000	1000.0	1003.0	950.5	17.5	945.1	21.7	932.8	27.0	915.6	34.3
1100 ⁽¹⁾	1100.0	1103.3	1045.5	19.3	1039.6	24.0	1026.1	29.7	1007.2	37.9
1200	1200.0	1203.6	1140.6	21.1	1134.1	26.2	1119.4	32.4	1098.8	41.4

TOM® PVC-O pipes are supplied in total length of 6.00 metres (including the length limit mark for the socket). The inside diameters may be subjected to variation according to manufacturing tolerances. 5.95 metres for export purposes and other lengths upon request. Consult manufacturing specifications.

(1) Items upon request. Consult delivery time.

SIRIM - Product Certification License
 Nº PC002014 according to ISO 16422



AENOR Product Certification



nº 001/007104 according to UNE-EN 17176-1
 nº 001/006537 according to ISO 16422

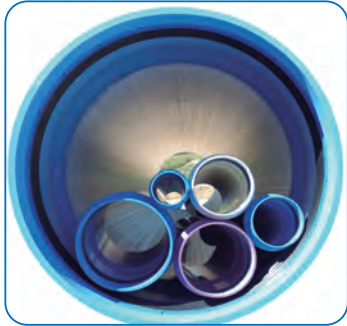
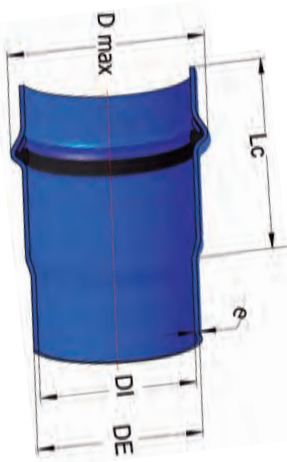

Packaging

TOM® PVC-O 500 Pipe

DN	Pipes/ Pallet	Pallet/ Truck	Pipes/ Truck	Metres ⁽¹⁾ / Truck	Pallet Width	Pallet Height	Pallet Length	Pallet Weight			
								PN12.5	PN16	PN20	PN25
mm	pipes	pallet	pipes	m	mm	mm	mm	kg	kg	kg	kg
90	115	8	920	5520	1190	885	6200	736	828	794	966
110	76	8	608	3648	1190	885	6200	714	638	775	935
125	60	12	720	4284	1220	850	6135	725	725	795	1025
140	45	12	540	3213	1220	850	6140	650	655	750	965
160	28	8	224	1344	1100	795	6240	484	521	610	739
200	18	8	144	864	1100	795	6260	486	518	610	745
225	14	16	224	1333	1220	700	6190	480	530	603	780
250	11	8	88	528	1100	795	6320	465	488	585	706
315	13	6	78	468	2310	670	6220	865	920	1089	1326
355	11	6	66	396	2150	740	6300	930	990	1170	1426
400	9	4	36	216	2020	850	6220	958	1031	1211	1480
450	5	6	30	180	2270	550	6220	685	723	860	1098
500	4	6	24	144	2020	600	6220	675	715	850	1085
630	3	6	18	108	1910	730	6220	800	851	1005	1292
710	3	6	18	107	2200	810	6425	1010	1105	1270	1645
800	2	6	18	107	2400	900	6425	1270	1400	1605	2080
900	2	4	8	48	1800	1000	6480	1070	1180	1425	1765
1000	2	4	8	48	2000	1100	6515	1315	1450	1670	2160
1100	2	4	8	48	2000	1250	6540	1585	1750	2120	2630
1200	2	4	8	48	2000	1350	6575	1885	2080	2520	3125

(1) Nominal metres (6.00 metres per pipe). The effective length is the total length minus the length limit marked for the assembly. 5.95 metres for export purposes. Other packagings or lengths upon request.
The combined pallet height shall not exceed 2,400 mm for a standard truck.
In case the load exceeds the height of 2,400 mm, it will be necessary to use a special truck.



Joins and Watertight Seals

The connection is done by introducing the male part of the pipe in the socket of the other where the elastic joint is placed. The watertight seal includes a Polypropylene ring and a synthetic EPDM rubber lip which allows the seal to be integrated with the pipe, avoiding joint displacement or movement while the installation is taking place.

Nominal Diameter (DN)	Socket Length (SL)	Maximum Diameter (D max)	Length limit mark for the assembly of the pipes (1)			
			PN12.5	PN16	PN20	PN25
mm	mm	mm	mm	mm	mm	mm
90	165	117	138	137	137	133
110	180	140	151	150	150	146
125	210	154	179	176	173	168
140	230	174	190	187	183	176
160	270	197	226	222	217	209
200	305	243	255	251	245	234
225	335	271	281	277	270	258
250	345	301	287	282	274	261
315	375	374	314	308	298	283
355	420	419	355	349	337	320
400	485	472	409	401	385	365
450	475	527	392	383	369	342
500	475	587	385	375	359	329
630	530	734	384	376	360	340
710	565	815	392	383	369	342
800	475	925	385	375	359	329
900	565	1034	464	453	434	401
1000	565	1143	455	443	424	376
1100	590	1250	475	461	431	382
1200	615	1360	487	472	447	403

(1) TOM® pipes have a mark in the spigot, being the limit mark to which the male end of the pipe should be introduced during installation and thus assure water-tightness.



The length limit mark for the assembly of the pipes is the distance from the beveled end of the pipe to the printed cutting mark.



Assembly

In order to do the assembly is necessary to apply lubricant on the chamfer of the spigot end and in the synthetic EPDM rubber ring joint, and push by hand until the mark of the spigot end is no longer seen.

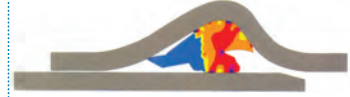

Apply lubricant on the chamfer of the spigot end and in the synthetic EPDM rubber ring joint.



Align the pipe and place the spigot end inside the socket or bell.



Firmly push the free end into the other pipe. Introduce until the end marked is no longer seen.

Fittings

TAPPING SADDLES

Allow connecting the pipe in the perpendicular direction to all kinds of fittings (house connections, valves, purges, vents, etc). They are available with screws ends and flange ends.



The saddle must become in solidarity with the pipe. Multidiameter saddles must not be used, but specific PVC saddles for each DN.

ANTI-TRACTION SYSTEM FLANGE

Allows connecting the spigot ends to all kinds of fittings with connection to a flange (valves, elbows, t's, DN reductions, caps, etc).



Anti-traction system makes the pipe absolutely fixed to the flange.

EURO TYPE PLUG FITTINGS

Connecting the fitting directly to the pipe allows us to have deviations, reductions and connections on the net (elbows, tees, DN reductions, etc).



It is very important to fix the fitting to the ground in order to guaranty the net structural resistance.

A wide range of fittings can be used with TOM® pipes. Consult our technical service to receive advise on the fittings that may be used.

ecoFITTOM

With **ecoFITTOM®**, the **first fittings in the world in PVC-O**, Molecor offers a continuous system in PVC-O; this material continuity guarantees the same hydraulic and mechanical properties in the different elements of the network, in the pipes as well as in the fittings. Moreover **ecoFITTOM®** PVC-O fittings are fully compatible with PVC-U pipes (EN ISO 1452) and with pipes of other materials.

These fittings are manufactured according to the Standard **UNE-CEN/TS 17176-3** "Piping systems in plastic materials for water supply, irrigation, sanitation, sewerage, buried or aerial, with pressure. Poly (vinyl chloride) unplasticized oriented (PVC-O) . Part 3: Fittings" (identical to CEN/TS 17176-3) and with the International Technical Specification ISO/TS 16422-3 'Pipes and joints made of oriented unplasticized poly (vinyl chloride) (PVC-O) for the conveyance of water under pressure-Part 3:Fitting'.



SIRIM Product Certification License N° PC011357 according to UNE-CEN/TS 17176-3.



AENOR Product certification n° 001/007103 according to UNE-CEN/TS 17176-3.



Technical specifications

Body	Seal type	PN Classification (bar)
Oriented unplasticized poly(vinyl chloride) (PVC-O)	Elastomer EPDM with PP stiffner ring	16
	Standard: EN 681-1	

ecoFITTOM® are provided with a proven watertightness seal that includes a polypropylene ring and a synthetic EPDM rubber lip which allows the seal to be integrated with the fitting, avoiding joint displacement or movement while the installation is taking place.

PROCESS FOR OBTAINING PVC-O FITTINGS

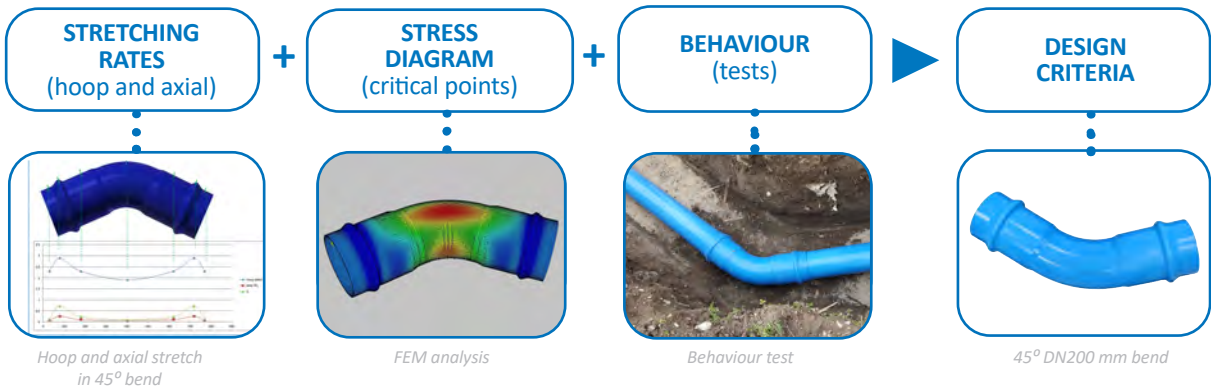

11.25° Socketed bend

DN	PN	Reference	ømax	L (mm)	Z (mm)	Radius (mm)	Weight (Kg)
110	10/16	F110C1116B	140	460	50	165	0.89
125	10/16	F125C1116B	155	500	55	187.5	1.27
140	10/16	F140C1116B	175	530	60	210	1.68
160	10/16	F160C1116B	200	540	65	240	2.11
200	10/16	F200C1116B	245	600	75	300	3.81
225	10/16	F225C1116B	270	645	85	340	5.38
250	10/16	F250C1116B	305	695	90	375	6.72
315	10/16	F315C1116B	375	815	110	475	12.50
400	10/16	F400C1116B	475	940	135	600	23.20

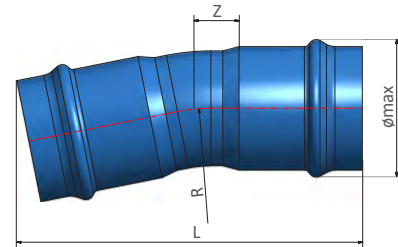

22.5° Socketed bend

DN	PN	Reference	ømax	L (mm)	Z (mm)	Radius (mm)	Weight (Kg)
110	10/16	F110C2216B	140	490	65	165	0.96
125	10/16	F125C2216B	155	535	75	187.5	1.37
140	10/16	F140C2216B	175	565	80	210	1.81
160	10/16	F160C2216B	200	585	90	240	2.37
200	10/16	F200C2216B	245	660	105	300	4.20
225	10/16	F225C2216B	270	710	120	340	5.94
250	10/16	F250C2216B	305	770	130	375	7.49
315	10/16	F315C2216B	375	915	155	475	14.04
400	10/16	F400C2216B	475	1070	195	600	26.35

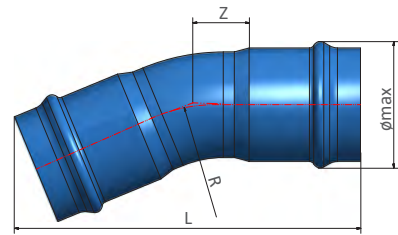

45° Socketed bend

DN	PN	Reference	ømax	L (mm)	Z (mm)	Radius (mm)	Weight (Kg)
110	10/16	F110C4516B	140	600	145	300	1.30
125	10/16	F125C4516B	155	570	115	187.5	1.56
140	10/16	F140C4516B	175	605	130	210	2.08
160	10/16	F160C4516B	200	640	140	240	2.71
200	10/16	F200C4516B	245	735	170	300	4.99
225	10/16	F225C4516B	270	840	195	340	7.06
250	10/16	F250C4516B	305	875	210	375	9.03
315	10/16	F315C4516B	375	940	140	300	14.87
400	10/16	F400C4516B	475	1250	330	600	32.64

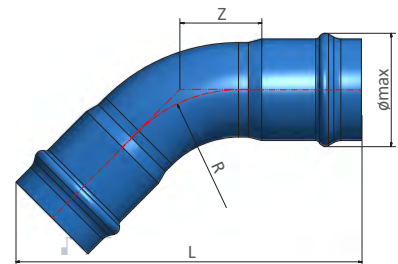

90° Socketed bend

DN	PN	Reference	ømax	L (mm)	Z (mm)	Radius (mm)	Weight (Kg)
110	10/16	F110C9016B	143	450	200	165	1.35
125	10/16	F125C9016B	155	490	225	187.5	1.94
140	10/16	F140C9016B	175	535	250	210	2.62
160	10/16	F160C9016B	198	565	275	240	3.52
200	10/16	F200C9016B	244	680	345	300	6.56
225	10/16	F225C9016B	270	750	370	340	9.30
250	10/16	F250C9016B	305	800	430	375	12.10
315	10/16	F315C9016B	375	850	380	315	19.16
400*	10/16	F400C9016B	472	900	375	300	32.64

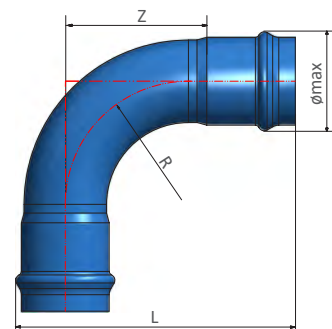

* Available under request

Socketed reducer

DN/DN	PN	Reference	ømax	L (mm)	Z (mm)	Weight (Kg)
110 / 90	10/16	F110R09016B	140	385	55	0.78
125 / 110	10/16	F125R11016B	155	450	80	1.17
140 / 110	10/16	F140R11016B	175	465	90	1.54
160 / 110	10/16	F160R11016B	200	480	105	1.95
160 / 140	10/16	F160R14016B	200	455	60	1.78
200 / 160	10/16	F200R16016B	245	525	100	3.33
225 / 160	10/16	F225R16016B	270	585	195	4.98
225 / 200	10/16	F225R20016B	270	510	80	4.31
250 / 200	10/16	F250R20016B	305	585	120	5.95
315 / 250	10/16	F315R25016B	375	690	155	11.05
400 / 315	10/16	F400R31516B	475	790	155	19.39

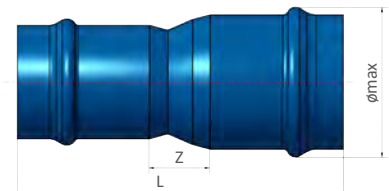

Coupler

DN	PN	Reference	ømax	L (mm)	Z (mm)	Weight (Kg)
110	10/16	F110M16B	140	420	70	0.83
125	10/16	F125M16B	155	455	75	1.17
140	10/16	F140M16B	175	465	80	1.54
160	10/16	F160M16B	200	490	85	1.91
200	10/16	F200M16B	245	530	95	3.41
225	10/16	F225M16B	270	580	115	4.87
250	10/16	F250M16B	305	620	120	6.06
315	10/16	F315M16B	375	715	145	11.34
400	10/16	F400M16B	475	820	190	21.12

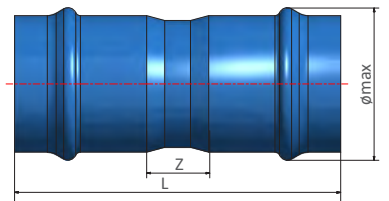

Sliding coupler

DN	PN	Reference	ømax	L (mm)	Z (mm)	Weight (Kg)
110	10/16	F110MR16B	140	420	-	0.83
125	10/16	F125MR16B	155	455	-	1.17
140	10/16	F140MR16B	175	465	-	1.54
160	10/16	F160MR16B	200	490	-	1.91
200	10/16	F200MR16B	245	530	-	3.41
225	10/16	F225MR16B	270	580	-	4.87
250	10/16	F250MR16B	305	620	-	6.06
315	10/16	F315MR16B	375	715	-	11.34
400	10/16	F400MR16B	475	820	-	21.12

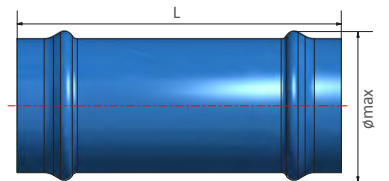

Applications

SUPPLYING - PUMPING (blue / white TOM®)

Conduits for potable water transport. It includes water abstraction and water distribution network to city centers, urban network and industrial areas, and water transfer to tanks and reservoirs.



RECLAIMED WATER (purple TOM®)

Pipelines for transport of water that have been treated to remove impurities.



IRRIGATION (blue TOM®)

Water transport pipes for irrigation purposes. It includes irrigated land pipelines, water transfer to tanks and reservoirs.



OTHER APPLICATIONS

- Sewage
- Fire Protection Nets
- Industrial Applications
- Infrastructural Nets

Key Factors for Optimizing Design

Hydraulic Design

Whether designing a pumping system or a gravity-enabled pipe system, deciding the dimensions of the pipes involves **calculating losses in the terms of load, flow-volume and flow speed**.

There are several methodologies for calculating these values. The most commonly used are the Hazen-Williams and Prandtl-Colebrook-White formulas.

Flow-volume (l/s) = speed (m/s) · section · (m²) 10³

Hazen-Williams Formula:

$$V = 0.355 \cdot C \cdot D_i^{0.63} \cdot J^{0.54}$$

Prandtl -Colebrook-White Formula

$$V = -2\sqrt{2 \cdot g \cdot D_i \cdot J} \cdot \log\left(\frac{K_a}{3.71 \cdot D_i} + \frac{2,51 \cdot v}{D_i \sqrt{2 \cdot g \cdot D_i \cdot J}}\right)$$

V = Average Speed in m/s

D_i = Internal Diameter in m

J = Pressure loss in m/m

C = Hazen-Williams Roughness Constant (for PVC-O; C = 150)

g = Gravity acceleration in m/s² (9.81 m/s²)

k_a = Absolute roughness in metres (for PVC-O; k_a = 0.007 · 10⁻³ m)

v = Kinematic viscosity of the fluid (m²/s) (for water at 20 °C; v = 1.0 · 10⁻⁶)

Another factor to be taken into account is the heat loss produced by fittings (elbows, reducers, tees, etc.) and valves.

There are tables available for calculating heat loss, flow and speeds using the Hazen-Williams formula. Flow speed must be determined taking into account different economical factors (optimization of the investment in terms of water pumping) and the admissible values for water hammers.

In general, it is established as the minimum value for avoiding sediments 0.5 m/s and as the maximum values between 2.0 m/s and 2.5 m/s, depending on the diameter of the pipe.

Geopositioning and traceability

The new **geoTOM**[®] application offers complete traceability of each **TOM**[®] and **ecoFIT**[®] product and allows to geoposition installed pieces on the network easily and rapidly with a smartphone.

Discover
GEO TOM
through this QR:



Mechanical calculation

Mechanical Calculation Software TOM[®] “**tomcalculation**” generates the results for different stresses and loads that the pipe will withstand as well as safety coefficients for burst and compression.

The software is based on the following standards:

- ATV-DVWK-A 127E: “Static Calculation of Drains and Sewers”.
- UNE 53331: “Unplastized poly(vinyl chloride) (PVC-U), oriented unplasticized poly(vinyl chloride) (PVC-O), polyethylene (PE) and polypropylene (PP) pipes. Criterion for the assessment of pipes for plastics piping systems with car without pressure under external loads”.



TOM



www.tomcalculation.com

Pressure loss tables

TOM® PVC-O 500 PN12.5

Pipe head loss is the energy of a hydraulic fluid that is lost along itself due to friction.

Below is the calculation of estimated water speeds depending on the selected pipe for installation.

Internal Diameter	DN90 PN12.5 84.8		DN110 PN12.5 103.6		DN125 PN12.5 117.8		DN140 PN12.5 132.3		DN160 PN12.5 152.1		DN200 PN12.5 190.1	
	Flow	J	Flow	J	Flow	J	Flow	J	Flow	J	Flow	J
Speed	l/s	m/km	l/s	m/km	l/s	m/km	l/s	m/km	l/s	m/km	l/s	m/km
0.1	0.56	0.16	0.84	0.12	1.09	0.11	1.37	0.09	1.82	0.08	2.84	0.06
0.2	1.13	0.57	1.69	0.46	2.18	0.39	2.75	0.34	3.63	0.29	5.68	0.22
0.3	1.69	1.21	2.53	0.96	3.27	0.83	4.12	0.72	5.45	0.61	8.51	0.47
0.4	2.26	2.07	3.37	1.64	4.36	1.41	5.50	1.23	7.27	1.05	11.35	0.81
0.5	2.82	3.12	4.21	2.47	5.45	2.13	6.87	1.86	9.08	1.58	14.19	1.22
0.6	3.39	4.39	5.06	3.48	6.54	2.99	8.25	2.61	10.90	2.22	17.03	1.71
0.7	3.95	5.83	5.90	4.62	7.63	3.98	9.62	3.47	12.72	2.95	19.87	2.28
0.8	4.52	7.48	6.74	5.91	8.72	5.09	11.00	4.45	14.54	3.78	22.71	2.91
0.9	5.08	9.29	7.59	7.37	9.81	6.34	12.37	5.53	16.35	4.70	25.54	3.62
1.0	5.65	11.31	8.43	8.95	10.90	7.70	13.75	6.73	18.17	5.71	28.38	4.40
1.1	6.21	13.47	9.27	10.67	11.99	9.19	15.12	8.02	19.99	6.82	31.22	5.26
1.2	6.78	15.85	10.12	12.55	13.08	10.80	16.50	9.43	21.80	8.01	34.06	6.17
1.3	7.34	18.36	10.96	14.55	14.17	12.52	17.87	10.93	23.62	9.29	36.90	7.16
1.4	7.91	21.09	11.80	16.68	15.26	14.36	19.25	12.54	25.44	10.66	39.74	8.22
1.5	8.47	23.94	12.64	18.94	16.35	16.32	20.62	14.25	27.25	12.11	42.57	9.33
1.6	9.04	27.00	13.49	21.37	17.44	18.39	22.00	16.06	29.07	13.64	45.41	10.52
1.7	9.60	30.18	14.33	23.90	18.53	20.58	23.37	17.97	30.89	15.27	48.25	11.77
1.8	10.17	33.59	15.17	26.56	19.62	22.87	24.74	19.97	32.71	16.98	51.09	13.08
1.9	10.73	37.09	16.02	29.38	20.71	25.28	26.12	22.08	34.52	18.76	53.93	14.46
2.0	11.30	40.82	16.86	32.30	21.80	27.80	27.49	24.27	36.34	20.63	56.77	15.90
2.1	11.86	44.65	17.70	35.34	22.89	30.43	28.87	26.57	38.16	22.58	59.60	17.40
2.2	12.43	48.70	18.55	38.55	23.98	33.17	30.24	28.96	39.97	24.61	62.44	18.97
2.3	12.99	52.85	19.39	41.84	25.07	36.02	31.62	31.45	41.79	26.72	65.28	20.60
2.4	13.55	57.14	20.23	45.26	26.16	38.97	32.99	34.02	43.61	28.92	68.12	22.29
2.5	14.12	61.67	21.07	48.80	27.25	42.03	34.37	36.70	45.42	31.18	70.96	24.04
2.6	14.68	66.28	21.92	52.51	28.34	45.20	35.74	39.46	47.24	33.53	73.80	25.85
2.7	15.25	71.12	22.76	56.30	29.43	48.47	37.12	42.33	49.06	35.97	76.63	27.72
2.8	15.81	76.04	23.60	60.21	30.52	51.85	38.49	45.27	50.88	38.48	79.47	29.65
2.9	16.38	81.19	24.45	64.28	31.61	55.33	39.87	48.32	52.69	41.05	82.31	31.65
3.0	16.94	86.41	25.29	68.43	32.70	58.91	41.24	51.44	54.51	43.71	85.15	33.70
3.1	17.51	91.87	26.13	72.70	33.79	62.60	42.62	54.67	56.33	46.46	87.99	35.81
3.2	18.07	97.38	26.97	77.09	34.88	66.39	43.99	57.97	58.14	49.26	90.82	37.97
3.3	18.64	103.15	27.82	81.65	35.97	70.29	45.37	61.38	59.96	52.15	93.66	40.20
3.4	19.20	108.96	28.66	86.27	37.06	74.28	46.74	64.86	61.78	55.12	96.50	42.49
3.5	19.77	115.03	29.50	91.02	38.15	78.38	48.11	68.42	63.59	58.15	99.34	44.83
3.6	20.33	121.14	30.35	95.93	39.24	82.58	49.49	72.10	65.41	61.27	102.18	47.23
3.7	20.90	127.50	31.19	100.91	40.33	86.88	50.86	75.84	67.23	64.46	105.02	49.69
3.8	21.46	133.90	32.03	106.00	41.42	91.27	52.24	79.70	69.04	67.71	107.85	52.20
3.9	22.03	140.56	32.88	111.27	42.51	95.77	53.61	83.61	70.86	71.06	110.69	54.78
4.0	22.59	147.25	33.72	116.59	43.60	100.37	54.99	87.64	72.68	74.47	113.53	57.41

TOM® PVC-O 500 PN12.5

Pipe head loss is the energy of a hydraulic fluid that is lost along itself due to friction.

Below is the calculation of estimated water speeds depending on the selected pipe for installation.

DN225 PN12.5 213.9		DN250 PN12.5 237.6		DN315 PN12.5 299.4		DN355 PN12.5 337.4		DN400 PN12.5 380.2		DN450 PN12.5 427.7		DN500 PN12.5 475.2		DN630 PN12.5 598.8		DN710 PN12.5 674.8		DN800 PN12.5 760.4		DN900 PN12.5 855.4		DN1000 PN12.5 950.5		DN1100 PN12.5 1045.5		DN1200 PN12.5 1140.6	
Flow	J	Flow	J	Flow	J	Flow	J	Flow	J	Flow	J	Flow	J	Flow	J	Flow	J	Flow	J	Flow	J	Flow	J	Flow	J	Flow	J
l/s	m/km	l/s	m/km	l/s	m/km	l/s	m/km	l/s	m/km	l/s	m/km	l/s	m/km	l/s	m/km	l/s	m/km	l/s	m/km	l/s	m/km	l/s	m/km	l/s	m/km	l/s	m/km
3.59	0.05	4.43	0.05	7.04	0.04	8.94	0.03	11.35	0.03	14.37	0.02	17.74	0.02	28.16	0.02	35.76	0.01	45.41	0.01	57.47	0.01	70.96	0.01	85.85	0.01	102.18	0.01
7.19	0.19	8.87	0.17	14.08	0.13	17.88	0.11	22.71	0.10	28.73	0.09	35.47	0.08	56.32	0.06	71.53	0.05	90.82	0.04	114.94	0.04	141.91	0.03	171.70	0.03	204.36	0.03
10.78	0.41	13.30	0.37	21.12	0.28	26.82	0.24	34.06	0.21	43.10	0.18	53.21	0.16	84.48	0.12	107.29	0.11	136.24	0.09	172.40	0.08	212.87	0.07	257.55	0.06	306.53	0.06
14.37	0.70	17.74	0.62	28.16	0.48	35.76	0.41	45.41	0.36	57.47	0.31	70.94	0.28	112.65	0.21	143.05	0.18	181.65	0.16	229.87	0.14	283.83	0.12	343.40	0.11	408.71	0.10
17.97	1.06	22.17	0.94	35.20	0.72	44.70	0.62	56.77	0.54	71.84	0.47	88.68	0.42	140.81	0.32	178.82	0.28	227.06	0.24	287.34	0.21	354.78	0.19	429.25	0.17	510.89	0.15
21.56	1.49	26.60	1.32	42.24	1.01	53.65	0.88	68.12	0.76	86.20	0.66	106.41	0.59	168.97	0.45	214.58	0.39	272.47	0.34	344.81	0.30	425.74	0.26	515.10	0.23	613.07	0.21
25.15	1.98	31.04	1.75	49.28	1.34	62.59	1.17	79.47	1.01	100.57	0.88	124.15	0.78	197.13	0.60	250.34	0.52	317.89	0.45	402.28	0.39	496.70	0.35	600.95	0.31	715.24	0.28
28.75	2.54	35.47	2.25	56.32	1.71	71.53	1.49	90.82	1.30	114.94	1.13	141.88	1.00	225.29	0.76	286.11	0.66	363.30	0.58	459.75	0.50	567.65	0.45	686.80	0.40	817.42	0.36
32.34	3.16	39.90	2.79	63.36	2.13	80.47	1.86	102.18	1.61	129.30	1.41	159.62	1.24	253.45	0.95	321.87	0.83	408.71	0.72	517.21	0.63	638.61	0.55	772.65	0.50	919.60	0.45
35.93	3.84	44.34	3.40	70.40	2.59	89.41	2.26	113.53	1.96	143.67	1.71	177.35	1.51	281.61	1.15	357.64	1.00	454.12	0.87	574.68	0.76	709.57	0.67	858.50	0.60	1021.78	0.54
39.53	4.58	48.77	4.05	77.44	3.09	98.35	2.69	124.88	2.34	158.04	2.04	195.09	1.80	309.77	1.38	393.40	1.20	499.54	1.04	632.15	0.91	780.52	0.80	944.34	0.72	1123.96	0.65
43.12	5.38	53.21	4.76	84.48	3.63	107.29	3.16	136.24	2.75	172.40	2.40	212.83	2.12	337.94	1.62	429.16	1.41	544.95	1.22	689.62	1.07	851.48	0.94	1030.19	0.84	1226.13	0.76
46.71	6.24	57.64	5.52	91.52	4.21	116.23	3.67	147.59	3.19	186.77	2.78	230.56	2.46	366.10	1.88	464.93	1.63	590.36	1.42	747.09	1.24	922.44	1.09	1116.04	0.98	1328.31	0.88
50.31	7.16	62.07	6.33	98.56	4.83	125.17	4.21	158.94	3.66	201.14	3.19	248.30	2.82	394.26	2.15	500.69	1.87	635.77	1.63	804.56	1.42	993.40	1.26	1201.89	1.12	1430.49	1.02
53.90	8.13	66.51	7.20	105.61	5.49	134.11	4.78	170.30	4.16	215.51	3.62	266.03	3.20	422.42	2.45	536.45	2.13	681.19	1.85	862.02	1.61	1064.35	1.43	1287.74	1.28	1532.67	1.15
57.50	9.17	70.94	8.11	112.65	6.19	143.05	5.39	181.65	4.68	229.87	4.08	283.77	3.61	450.58	2.76	572.22	2.40	726.60	2.09	919.49	1.82	1135.31	1.61	1373.59	1.44	1634.85	1.30
61.09	10.26	75.38	9.07	119.69	6.93	151.99	6.02	193.00	5.24	244.24	4.57	301.50	4.04	478.74	3.08	607.98	2.68	772.01	2.33	976.96	2.03	1206.27	1.80	1459.44	1.61	1737.02	1.45
64.68	11.40	79.81	10.09	126.73	7.70	160.94	6.70	204.36	5.83	258.61	5.08	319.24	4.49	506.90	3.43	643.74	2.98	817.42	2.59	1034.43	2.26	1277.22	2.00	1545.29	1.79	1839.20	1.62
68.28	12.60	84.24	11.15	133.77	8.51	169.88	7.40	215.71	6.44	272.97	5.61	336.97	4.96	535.07	3.79	679.51	3.30	862.83	2.87	1091.90	2.50	1348.18	2.21	1631.14	1.98	1941.38	1.79
71.87	13.86	88.68	12.26	140.81	9.36	178.82	8.14	227.06	7.08	287.34	6.17	354.71	5.46	563.23	4.17	715.27	3.63	908.25	3.15	1149.37	2.75	1419.14	2.43	1716.99	2.18	2043.56	1.96
75.46	15.17	93.11	13.42	147.85	10.24	187.76	8.91	238.41	7.75	301.71	6.76	372.44	5.98	591.39	4.56	751.03	3.97	953.66	3.45	1206.83	3.01	1490.09	2.66	1802.84	2.38	2145.73	2.15
79.06	16.53	97.55	14.63	154.89	11.17	196.70	9.71	249.77	8.45	316.08	7.36	390.18	6.51	619.55	4.97	786.80	4.33	999.07	3.76	1264.30	3.28	1561.05	2.90	1888.69	2.60	2247.91	2.34
82.65	17.95	101.98	15.88	161.93	12.12	205.64	10.55	261.12	9.17	330.44	8.00	407.92	7.07	647.71	5.40	822.56	4.70	1044.48	4.09	1321.77	3.56	1632.01	3.15	1974.54	2.82	2350.09	2.55
86.24	19.42	106.41	17.18	168.97	13.12	214.58	11.41	272.47	9.93	344.81	8.65	425.65	7.65	675.87	5.84	858.32	5.08	1089.90	4.42	1379.24	3.85	1702.96	3.41	2060.39	3.05	2452.27	2.75
89.84	20.95	110.85	18.53	176.01	14.15	223.52	12.31	283.83	10.71	359.18	9.33	443.39	8.25	704.03	6.30	894.09	5.48	1135.31	4.77	1436.71	4.16	1773.92	3.67	2146.24	3.29	2554.45	2.97
93.43	22.53	115.28	19.93	183.05	15.22	232.46	13.23	295.18	11.51	373.54	10.03	461.12	8.87	732.20	6.78	929.85	5.89	1180.72	5.13	1494.18	4.47	1844.88	3.95	2232.09	3.54	2656.62	3.19
97.02	24.16	119.71	21.37	190.09	16.32	241.40	14.19	306.53	12.35	387.91	10.76	478.86	9.52	760.36	7.27	965.61	6.32	1226.13	5.50	1551.64	4.79	1915.83	4.24	2317.94	3.79	2758.80	3.43
100.62	25.84	124.15	22.86	197.13	17.45	250.34	15.18	317.89	13.21	402.28	11.51	496.59	10.18	788.52	7.77	1001.38	6.76	1271.55	5.88	1609.11	5.13	1986.79	4.53	2403.79	4.06	2860.98	3.66
104.21	27.58	128.58	24.39	204.17	18.63	259.29	16.20	329.24	14.09	416.65	12.28	514.33	10.86	816.68	8.29	1037.14	7.22	1316.96	6.28	1666.58	5.47	2057.75	4.84	2489.64	4.33	2963.16	3.91
107.80	29.36	133.02	25.98	211.21	19.83	268.23	17.25	340.59	15.01	431.01	13.08	532.06	11.57	844.84	8.83	1072.91	7.68	1362.37	6.68	1724.05	5.83	2128.70	5.15	2575.49	4.61	3065.33	4.16
111.40	31.20	137.45	27.60	218.25	21.07	277.17	18.33	351.95	15.95	445.38	13.90	549.80	12.29	873.00	9.39	1108.67	8.16	1407.78	7.10	1781.52	6.19	2199.66	5.47	2661.34	4.90	3167.51	4.42
114.99	33.09	141.88	29.27	225.29	22.35	286.11	19.44	363.30	16.91	459.75	14.74	567.54	13.04	901.16	9.95	1144.43	8.66	1453.20	7.53	1838.99	6.56	2270.62	5.80	2747.19	5.19	3269.69	4.69
118.58	35.03	146.32	30.99	232.33	23.66	295.05	20.58	374.65	17.90	474.11	15.61	585.27	13.80	929.32	10.54	1180.20	9.17	1498.61	7.97	1896.45	6.95	2341.57	6.15	2833.03	5.50	3371.87	4.97
122.18	37.02	150.75	32.75	239.37	25.01	303.99	21.75	386.01	18.92	488.48	16.49	603.01	14.59	957.49	11.14	1215.96	9.69	1544.02	8.43	1953.92	7.34	2412.53	6.49	2918.88	5.81	3474.05	5.25
125.77	39.06	155.19	34.56	246.41	26.38	312.93	22.95	397.36	19.97	502.85	17.40	620.74	15.39	985.65	11.75	1251.72	10.22	1589.43	8.89	2011.39	7.75	2483.49	6.85	3004.73	6.13	3576.22	5.54
129.36	41.15	159.62	36.41	253.45	27.80	321.87	24.18	408.71	21.03	517.21	18.33	638.48	16.21	1013.81	12.38	1287.49	10.77	1634.85	9.37	2068.86	8.17	2554.45	7.22	3090.58	6.46	3678.40	5.84
132.96	43.30	164.05	38.30	260.49	29.24	330.81	25.44	420.06	22.13	531.58	19.29	656.21	17.06	1041.97	13.02	1323.25	11.33	1680.26	9.86	2126.33	8.59	2625.40	7.60	3176.43	6.80	3780.58	6.14
136.55	45.49	168.49	40.24	267.53	30.73	339.75	26.73	431.42	23.25	545.95	20.27	673.95	17.92	1070.13	13.68	1359.01	11.90	1725.67	10.35	2183.80	9.02	2696.36	7.98	3262.28	7.14	3882.76	6.45
140.14	47.73	172.92	42.22	274.57	32.24	348.69	28.04	442.77	24.40	560.32	21.26	691.68	18.80	1098.29	14.36	1394.78	12.49	1771.08	10.86	2241.26	9.47	2767.32	8.37	3348.13	7.49	3984.93	6.77
143.74	50.03	177.35	44.25	281.61	33.79																						

Pressure loss tables
TOM® PVC-O 500 PN16

Pipe head loss is the energy of a hydraulic fluid that is lost along itself due to friction.

Below is the calculation of estimated water speeds depending on the selected pipe for installation.

Internal Diameter	DN90 PN16 84.3		DN110 PN16 103.1		DN125 PN16 117.8		DN140 PN16 132.3		DN160 PN16 151.2		DN200 PN16 189.0	
	Flow (m/s) l/s	J m/km	Flow l/s	J m/km	Flow l/s	J m/km	Flow l/s	J m/km	Flow l/s	J m/km	Flow l/s	J m/km
0.1	0.56	0.16	0.83	0.13	1.09	0.11	1.37	0.09	1.80	0.08	2.81	0.06
0.2	1.12	0.58	1.67	0.46	2.18	0.39	2.75	0.34	3.59	0.29	5.61	0.23
0.3	1.67	1.22	2.50	0.96	3.27	0.83	4.12	0.72	5.39	0.62	8.42	0.48
0.4	2.23	2.08	3.34	1.65	4.36	1.41	5.50	1.23	7.18	1.05	11.22	0.81
0.5	2.79	3.15	4.17	2.49	5.45	2.13	6.87	1.86	8.98	1.59	14.03	1.23
0.6	3.35	4.42	5.01	3.49	6.54	2.99	8.25	2.61	10.77	2.23	16.83	1.72
0.7	3.91	5.89	5.84	4.64	7.63	3.98	9.62	3.47	12.57	2.97	19.64	2.29
0.8	4.47	7.54	6.68	5.95	8.72	5.09	11.00	4.45	14.36	3.80	22.44	2.93
0.9	5.02	9.35	7.51	7.39	9.81	6.34	12.37	5.53	16.16	4.73	25.25	3.65
1.0	5.58	11.37	8.35	9.00	10.90	7.70	13.75	6.73	17.96	5.76	28.06	4.44
1.1	6.14	13.58	9.18	10.73	11.99	9.19	15.12	8.02	19.75	6.86	30.86	5.29
1.2	6.70	15.96	10.02	12.61	13.08	10.80	16.50	9.43	21.55	8.07	33.67	6.22
1.3	7.26	18.52	10.85	14.62	14.17	12.52	17.87	10.93	23.34	9.35	36.47	7.21
1.4	7.81	21.20	11.69	16.78	15.26	14.36	19.25	12.54	25.14	10.73	39.28	8.27
1.5	8.37	24.10	12.52	19.05	16.35	16.32	20.62	14.25	26.93	12.19	42.08	9.40
1.6	8.93	27.17	13.36	21.49	17.44	18.39	22.00	16.06	28.73	13.74	44.89	10.59
1.7	9.49	30.41	14.19	24.03	18.53	20.58	23.37	17.97	30.52	15.37	47.69	11.85
1.8	10.05	33.82	15.03	26.73	19.62	22.87	24.74	19.97	32.32	17.09	50.50	13.17
1.9	10.60	37.32	15.86	29.53	20.71	25.28	26.12	22.08	34.12	18.90	53.30	14.56
2.0	11.16	41.06	16.70	32.49	21.80	27.80	27.49	24.27	35.91	20.77	56.11	16.01
2.1	11.72	44.95	17.53	35.54	22.89	30.43	28.87	26.57	37.71	22.74	58.92	17.53
2.2	12.28	49.01	18.37	38.76	23.98	33.17	30.24	28.96	39.50	24.78	61.72	19.10
2.3	12.84	53.23	19.20	42.06	25.07	36.02	31.62	31.45	41.30	26.91	64.53	20.74
2.4	13.40	57.61	20.04	45.54	26.16	38.97	32.99	34.02	43.09	29.11	67.33	22.44
2.5	13.95	62.07	20.87	49.09	27.25	42.03	34.37	36.70	44.89	31.41	70.14	24.20
2.6	14.51	66.76	21.71	52.81	28.34	45.20	35.74	39.46	46.68	33.76	72.94	26.02
2.7	15.07	71.61	22.54	56.61	29.43	48.47	37.12	42.33	48.48	36.21	75.75	27.91
2.8	15.63	76.62	23.38	60.58	30.52	51.85	38.49	45.27	50.27	38.73	78.55	29.85
2.9	16.19	81.78	24.21	64.62	31.61	55.33	39.87	48.32	52.07	41.34	81.36	31.86
3.0	16.74	87.00	25.05	68.84	32.70	58.91	41.24	51.44	53.87	44.02	84.17	33.93
3.1	17.30	92.46	25.88	73.12	33.79	62.60	42.62	54.67	55.66	46.77	86.97	36.05
3.2	17.86	98.08	26.72	77.58	34.88	66.39	43.99	57.97	57.46	49.61	89.78	38.24
3.3	18.42	103.86	27.55	82.10	35.97	70.29	45.37	61.38	59.25	52.51	92.58	40.47
3.4	18.98	109.78	28.38	86.74	37.06	74.28	46.74	64.86	61.05	55.50	95.39	42.78
3.5	19.53	115.74	29.22	91.55	38.15	78.38	48.11	68.42	62.84	58.55	98.19	45.13
3.6	20.09	121.96	30.05	96.43	39.24	82.58	49.49	72.10	64.64	61.70	101.00	47.55
3.7	20.65	128.34	30.89	101.48	40.33	86.88	50.86	75.84	66.43	64.90	103.80	50.02
3.8	21.21	134.86	31.72	106.59	41.42	91.27	52.24	79.70	68.23	68.19	106.61	52.56
3.9	21.77	141.52	32.56	111.87	42.51	95.77	53.61	83.61	70.03	71.56	109.42	55.15
4.0	22.33	148.34	33.39	117.21	43.60	100.37	54.99	87.64	71.82	74.99	112.22	57.80

Pressure loss tables

TOM® PVC-O 500 PN16

Pipe head loss is the energy of a hydraulic fluid that is lost along itself due to friction.

Below is the calculation of estimated water speeds depending on the selected pipe for installation.

DN225 PN16 212.6		DN250 PN16 236.3		DN315 PN16 297.7		DN355 PN16 335.5		DN400 PN16 378.0		DN450 PN16 425.3		DN500 PN16 472.5		DN630 PN16 595.4		DN710 PN16 671.0		DN800 PN16 756.1		DN900 PN16 850.6		DN1000 PN16 945.1		DN1100 PN16 1039.6		DN1200 PN16 1134.1	
Flow	J	Flow	J	Flow	J	Flow	J	Flow	J	Flow	J	Flow	J	Flow	J	Flow	J	Flow	J	Flow	J	Flow	J	Flow	J	Flow	J
l/s	m/km	l/s	m/km	l/s	m/km	l/s	m/km	l/s	m/km	l/s	m/km	l/s	m/km	l/s	m/km	l/s	m/km	l/s	m/km	l/s	m/km	l/s	m/km	l/s	m/km	l/s	m/km
3.55	0.05	4.39	0.05	6.96	0.04	8.84	0.03	11.22	0.03	14.21	0.02	17.53	0.02	27.84	0.02	35.36	0.01	44.90	0.01	56.83	0.01	70.15	0.01	84.88	0.01	101.02	0.01
7.10	0.20	8.77	0.17	13.92	0.13	17.68	0.12	22.44	0.10	28.41	0.09	35.07	0.08	55.68	0.06	70.72	0.05	89.80	0.04	113.65	0.04	140.31	0.03	169.77	0.03	202.03	0.03
10.65	0.42	13.16	0.37	20.88	0.28	26.52	0.24	33.67	0.21	42.62	0.19	52.60	0.16	83.53	0.13	106.09	0.11	134.70	0.09	170.48	0.08	210.46	0.07	254.65	0.07	303.05	0.06
14.20	0.71	17.54	0.63	27.84	0.48	35.36	0.42	44.89	0.36	56.83	0.32	70.14	0.28	111.37	0.21	141.45	0.19	179.60	0.16	227.30	0.14	280.61	0.12	339.53	0.11	404.07	0.10
17.75	1.07	21.93	0.95	34.80	0.72	44.20	0.63	56.11	0.55	71.03	0.48	87.67	0.42	139.21	0.32	176.81	0.28	224.50	0.24	284.13	0.21	350.76	0.19	424.42	0.17	505.08	0.15
21.30	1.50	26.31	1.33	41.76	1.01	53.04	0.88	67.33	0.77	85.24	0.67	105.21	0.59	167.05	0.45	212.17	0.39	269.40	0.34	340.95	0.30	420.92	0.26	509.30	0.24	606.10	0.21
24.85	2.00	30.70	1.77	48.72	1.35	61.88	1.17	78.55	1.02	99.44	0.89	122.74	0.79	194.90	0.60	247.53	0.52	314.30	0.45	397.78	0.40	491.07	0.35	594.18	0.31	707.12	0.28
28.40	2.56	35.08	2.26	55.68	1.73	70.72	1.50	89.78	1.31	113.65	1.14	140.28	1.01	222.74	0.77	282.89	0.67	359.20	0.58	454.60	0.51	561.22	0.45	679.07	0.40	808.13	0.36
31.95	3.18	39.47	2.81	62.65	2.15	79.56	1.87	101.00	1.63	127.86	1.42	157.81	1.25	250.58	0.96	318.26	0.83	404.10	0.72	511.43	0.63	631.38	0.56	763.95	0.50	909.15	0.45
35.50	3.87	43.85	3.42	69.61	2.61	88.40	2.27	112.22	1.98	142.06	1.72	175.35	1.52	278.42	1.16	353.62	1.01	449.00	0.88	568.25	0.77	701.53	0.68	848.83	0.61	1010.17	0.55
39.05	4.61	48.24	4.08	76.57	3.11	97.25	2.71	123.44	2.36	156.27	2.05	192.88	1.82	306.27	1.39	388.98	1.21	493.90	1.05	625.08	0.91	771.68	0.81	933.72	0.72	1111.18	0.65
42.60	5.42	52.63	4.79	83.53	3.66	106.09	3.18	134.66	2.77	170.48	2.41	210.41	2.13	334.11	1.63	424.34	1.42	538.80	1.23	681.90	1.07	841.83	0.95	1018.60	0.85	1212.20	0.77
46.15	6.29	57.01	5.56	90.49	4.24	114.93	3.69	145.89	3.21	184.68	2.80	227.95	2.47	361.95	1.89	459.70	1.64	583.70	1.43	738.73	1.25	911.99	1.10	1103.48	0.99	1313.22	0.89
49.70	7.21	61.40	6.37	97.45	4.87	123.77	4.23	157.11	3.68	198.89	3.21	245.48	2.84	389.79	2.17	495.07	1.89	628.60	1.64	795.55	1.43	982.14	1.26	1188.37	1.13	1414.23	1.02
53.25	8.19	65.78	7.24	104.41	5.53	132.61	4.81	168.33	4.19	213.09	3.65	263.02	3.23	417.64	2.46	530.43	2.14	673.50	1.86	852.38	1.62	1052.29	1.44	1273.25	1.29	1515.25	1.16
56.80	9.23	70.17	8.16	111.37	6.23	141.45	5.42	179.55	4.72	227.30	4.11	280.55	3.64	445.48	2.78	565.79	2.41	718.40	2.10	909.20	1.83	1122.45	1.62	1358.13	1.45	1616.26	1.31
60.35	10.33	74.55	9.13	118.33	6.97	150.29	6.07	190.78	5.28	241.51	4.60	298.09	4.07	473.32	3.11	601.15	2.70	763.30	2.35	966.03	2.05	1192.60	1.81	1443.02	1.62	1717.28	1.46
63.90	11.48	78.94	10.15	125.29	7.75	159.13	6.74	202.00	5.87	255.71	5.11	315.62	4.52	501.16	3.45	636.51	3.00	808.20	2.61	1022.85	2.28	1262.75	2.01	1527.90	1.80	1818.30	1.63
67.45	12.69	83.32	11.22	132.25	8.57	167.97	7.45	213.22	6.48	269.92	5.65	333.16	5.00	529.01	3.82	671.88	3.32	853.10	2.89	1079.68	2.52	1332.90	2.23	1612.78	1.99	1919.31	1.80
71.00	13.96	87.71	12.34	139.21	9.42	176.81	8.20	224.44	7.13	284.13	6.21	350.69	5.50	556.85	4.20	707.24	3.65	898.00	3.17	1136.50	2.77	1403.06	2.45	1697.67	2.19	2020.33	1.98
74.55	15.28	92.10	13.50	146.17	10.31	185.65	8.97	235.66	7.80	298.33	6.80	368.22	6.02	584.69	4.59	742.60	3.99	942.90	3.48	1193.33	3.03	1473.21	2.68	1782.55	2.40	2121.35	2.17
78.10	16.65	96.48	14.72	153.13	11.24	194.49	9.78	246.89	8.51	312.54	7.41	385.76	6.56	612.53	5.01	777.96	4.35	987.80	3.79	1250.15	3.30	1543.36	2.92	1867.43	2.61	2222.36	2.36
81.65	18.08	100.87	15.98	160.09	12.20	203.33	10.62	258.11	9.24	326.74	8.05	403.29	7.12	640.38	5.44	813.32	4.73	1032.70	4.11	1306.98	3.58	1613.52	3.17	1952.32	2.84	2323.38	2.56
85.20	19.56	105.25	17.29	167.05	13.21	212.17	11.49	269.33	9.99	340.95	8.71	420.83	7.70	668.22	5.88	848.68	5.12	1077.61	4.45	1363.80	3.88	1683.67	3.43	2037.20	3.07	2424.40	2.77
88.75	21.10	109.64	18.65	174.02	14.24	221.01	12.39	280.55	10.78	355.16	9.39	438.36	8.31	696.06	6.34	884.05	5.52	1122.51	4.80	1420.63	4.18	1753.82	3.70	2122.08	3.31	2525.41	2.99
92.30	22.69	114.02	20.05	180.98	15.32	229.85	13.32	291.77	11.59	369.36	10.10	455.90	8.93	723.90	6.82	919.41	5.93	1167.41	5.16	1477.45	4.50	1823.97	3.98	2206.97	3.56	2626.43	3.22
95.85	24.33	118.41	21.51	187.94	16.43	238.69	14.29	303.00	12.43	383.57	10.83	473.43	9.58	751.75	7.32	954.77	6.36	1212.31	5.53	1534.28	4.82	1894.13	4.27	2291.85	3.82	2727.45	3.45
99.40	26.03	122.79	23.00	194.90	17.57	247.53	15.28	314.22	13.30	397.78	11.59	490.97	10.25	779.59	7.82	990.13	6.81	1257.21	5.92	1591.10	5.16	1964.28	4.56	2376.73	4.08	2828.46	3.69
102.95	27.77	127.18	24.55	201.86	18.75	256.37	16.31	325.44	14.19	411.98	12.37	508.50	10.94	807.43	8.35	1025.49	7.26	1302.11	6.32	1647.93	5.51	2034.43	4.87	2461.62	4.36	2929.48	3.94
106.50	29.57	131.56	26.14	208.82	19.96	265.21	17.36	336.66	15.11	426.19	13.17	526.04	11.64	835.27	8.89	1060.86	7.73	1347.01	6.73	1704.75	5.86	2104.59	5.19	2546.50	4.64	3030.50	4.19
110.05	31.43	135.95	27.78	215.78	21.21	274.05	18.45	347.88	16.05	440.39	13.99	543.57	12.37	863.12	9.45	1096.22	8.22	1391.91	7.15	1761.58	6.23	2174.74	5.51	2631.38	4.93	3131.51	4.45
113.60	33.33	140.34	29.46	222.74	22.50	282.89	19.57	359.11	17.03	454.60	14.84	561.10	13.12	890.96	10.02	1131.58	8.72	1436.81	7.58	1818.40	6.61	2244.89	5.84	2716.27	5.23	3232.53	4.72
117.15	35.28	144.72	31.19	229.70	23.82	291.74	20.72	370.33	18.03	468.81	15.71	578.64	13.89	918.80	10.61	1166.94	9.23	1481.71	8.03	1875.23	7.00	2315.04	6.19	2801.15	5.54	3333.55	5.00
120.70	37.29	149.11	32.96	236.66	25.17	300.58	21.90	381.55	19.05	483.01	16.60	596.17	14.68	946.64	11.21	1202.30	9.75	1526.61	8.48	1932.06	7.39	2385.20	6.54	2886.03	5.85	3434.56	5.29
124.25	39.35	153.49	34.78	243.62	26.56	309.42	23.10	392.77	20.10	497.22	17.52	613.71	15.49	974.49	11.83	1237.66	10.29	1571.51	8.95	1988.88	7.80	2455.35	6.90	2970.92	6.17	3535.58	5.58
127.80	41.45	157.88	36.64	250.58	27.98	318.26	24.34	403.99	21.18	511.43	18.46	631.24	16.32	1002.33	12.46	1273.03	10.84	1616.41	9.43	2045.71	8.22	2525.50	7.27	3055.80	6.50	3636.60	5.88
131.35	43.61	162.26	38.55	257.54	29.44	327.10	25.61	415.22	22.28	525.63	19.42	648.78	17.17	1030.17	13.11	1308.39	11.40	1661.31	9.92	2102.53	8.65	2595.66	7.65	3140.68	6.84	3737.61	6.18
134.90	45.82	166.65	40.50	264.50	30.93	335.94	26.90	426.44	23.41	539.84	20.40	666.31	18.04	1058.01	13.77	1343.75	11.98	1706.21	10.42	2159.36	9.08	2665.81	8.03	3225.57	7.19	3838.63	6.49
138.45	48.08	171.03	42.49	271.46	32.45	344.78	28.23	437.66	24.56	554.05	21.40	683.85	18.93	1085.86	14.45	1379.11	12.57	1751.11	10.94	2216.18	9.53	2735.96	8.43	3310.45	7.54	3939.65	6.81
142.00	50.38	175.42	44.54	278.42	34.01	353.62	29.58	448.88																			

Pressure loss tables

TOM® PVC-O 500 PN20

Pipe head loss is the energy of a hydraulic fluid that is lost along itself due to friction.

Below is the calculation of estimated water speeds depending on the selected pipe for installation.

Internal Diameter	DN90 PN20 84.3		DN110 PN20 103.0		DN125 PN20 117.1		DN140 PN20 131.1		DN160 PN20 149.8		DN200 PN20 187.3	
	Flow	J	Flow	J	Flow	J	Flow	J	Flow	J	Flow	J
Speed (m/s)	l/s	m/km	l/s	m/km	l/s	m/km	l/s	m/km	l/s	m/km	l/s	m/km
0.1	0.56	0.16	0.83	0.13	1.08	0.11	1.35	0.10	1.76	0.08	2.76	0.06
0.2	1.12	0.58	1.67	0.46	2.15	0.39	2.70	0.35	3.52	0.29	5.51	0.23
0.3	1.67	1.22	2.50	0.97	3.23	0.83	4.05	0.73	5.29	0.63	8.27	0.48
0.4	2.23	2.08	3.33	1.65	4.31	1.42	5.40	1.25	7.05	1.07	11.02	0.82
0.5	2.79	3.15	4.17	2.50	5.38	2.14	6.75	1.88	8.81	1.61	13.78	1.24
0.6	3.35	4.42	5.00	3.50	6.46	3.01	8.10	2.64	10.57	2.26	16.53	1.74
0.7	3.91	5.89	5.83	4.65	7.54	4.01	9.45	3.51	12.34	3.01	19.29	2.32
0.8	4.47	7.54	6.67	5.96	8.62	5.13	10.80	4.50	14.10	3.85	22.04	2.96
0.9	5.02	9.35	7.50	7.41	9.69	6.38	12.15	5.59	15.86	4.78	24.80	3.69
1.0	5.58	11.37	8.33	9.00	10.77	7.75	13.50	6.80	17.62	5.81	27.55	4.48
1.1	6.14	13.58	9.17	10.75	11.85	9.26	14.85	8.11	19.39	6.94	30.31	5.35
1.2	6.70	15.96	10.00	12.63	12.92	10.86	16.20	9.53	21.15	8.15	33.06	6.28
1.3	7.26	18.52	10.83	14.64	14.00	12.60	17.55	11.05	22.91	9.46	35.82	7.29
1.4	7.81	21.20	11.67	16.81	15.08	14.46	18.90	12.68	24.67	10.84	38.57	8.36
1.5	8.37	24.10	12.50	19.09	16.15	16.42	20.25	14.40	26.44	12.33	41.33	9.50
1.6	8.93	27.17	13.33	21.50	17.23	18.51	21.60	16.23	28.20	13.89	44.08	10.70
1.7	9.49	30.41	14.16	24.05	18.31	20.72	22.95	18.16	29.96	15.54	46.84	11.97
1.8	10.05	33.82	15.00	26.76	19.39	23.04	24.30	20.19	31.72	17.27	49.60	13.31
1.9	10.60	37.32	15.83	29.56	20.46	25.45	25.65	22.32	33.49	19.10	52.35	14.71
2.0	11.16	41.06	16.66	32.50	21.54	27.99	27.00	24.54	35.25	21.00	55.11	16.18
2.1	11.72	44.95	17.50	35.60	22.62	30.65	28.35	26.86	37.01	22.98	57.86	17.71
2.2	12.28	49.01	18.33	38.79	23.69	33.39	29.70	29.28	38.77	25.05	60.62	19.31
2.3	12.84	53.23	19.16	42.10	24.77	36.26	31.05	31.79	40.54	27.21	63.37	20.96
2.4	13.40	57.61	20.00	45.58	25.85	39.24	32.40	34.40	42.30	29.44	66.13	22.68
2.5	13.95	62.07	20.83	49.15	26.92	42.30	33.75	37.10	44.06	31.74	68.88	24.46
2.6	14.51	66.76	21.66	52.84	28.00	45.50	35.10	39.89	45.82	34.13	71.64	26.30
2.7	15.07	71.61	22.50	56.69	29.08	48.80	36.45	42.78	47.59	36.62	74.39	28.21
2.8	15.63	76.62	23.33	60.63	30.16	52.21	37.80	45.76	49.35	39.16	77.15	30.17
2.9	16.19	81.78	24.16	64.68	31.23	55.70	39.15	48.83	51.11	41.79	79.90	32.20
3.0	16.74	87.00	25.00	68.91	32.31	59.32	40.50	52.00	52.87	44.49	82.66	34.29
3.1	17.30	92.46	25.83	73.21	33.39	63.04	41.85	55.25	54.64	47.29	85.41	36.43
3.2	17.86	98.08	26.66	77.62	34.46	66.83	43.20	58.60	56.40	50.15	88.17	38.64
3.3	18.42	103.86	27.50	82.21	35.54	70.76	44.55	62.04	58.16	53.09	90.92	40.90
3.4	18.98	109.78	28.33	86.87	36.62	74.80	45.90	65.56	59.92	56.10	93.68	43.23
3.5	19.53	115.74	29.16	91.64	37.69	78.90	47.25	69.18	61.69	59.21	96.43	45.61
3.6	20.09	121.96	30.00	96.59	38.77	83.13	48.60	72.88	63.45	62.37	99.19	48.06
3.7	20.65	128.34	30.83	101.59	39.85	87.47	49.95	76.68	65.21	65.62	101.95	50.56
3.8	21.21	134.86	31.66	106.72	40.92	91.87	51.30	80.56	66.97	68.93	104.70	53.12
3.9	21.77	141.52	32.50	112.02	42.00	96.41	52.65	84.53	68.74	72.35	107.46	55.74
4.0	22.33	148.34	33.33	117.38	43.08	101.06	54.00	88.59	70.50	75.81	110.21	58.41

Pressure loss tables

TOM® PVC-O 500 PN20

Pipe head loss is the energy of a hydraulic fluid that is lost along itself due to friction.

Below is the calculation of estimated water speeds depending on the selected pipe for installation.

DN225 PN20 210.7		DN250 PN20 234.1		DN315 PN20 295.0		DN355 PN20 332.5		DN400 PN20 374.6		DN450 PN20 421.4		DN500 PN20 468.2		DN630 PN20 590.0		DN710 PN20 664.9		DN800 PN20 749.2		DN900 PN20 839.5		DN1000 PN20 932.8		DN1100 PN20 1026.1		DN1200 PN20 1119.4	
Flow	J	Flow	J	Flow	J	Flow	J	Flow	J	Flow	J	Flow	J	Flow	J	Flow	J	Flow	J	Flow	J	Flow	J	Flow	J	Flow	J
l/s	m/km	l/s	m/km	l/s	m/km	l/s	m/km	l/s	m/km	l/s	m/km	l/s	m/km	l/s	m/km	l/s	m/km	l/s	m/km	l/s	m/km	l/s	m/km	l/s	m/km	l/s	m/km
3.49	0.06	4.30	0.05	6.83	0.04	8.68	0.03	11.02	0.03	13.95	0.02	17.22	0.02	27.34	0.02	34.72	0.01	44.08	0.01	55.35	0.01	68.34	0.01	82.69	0.01	98.41	0.01
6.97	0.20	8.61	0.18	13.67	0.13	17.37	0.12	22.04	0.10	27.89	0.09	34.43	0.08	54.68	0.06	69.44	0.05	88.17	0.05	110.70	0.04	136.68	0.03	165.39	0.03	196.83	0.03
10.46	0.42	12.91	0.37	20.50	0.28	26.05	0.25	33.06	0.21	41.84	0.19	51.65	0.17	82.02	0.13	104.17	0.11	132.25	0.10	166.06	0.08	205.02	0.07	248.08	0.07	295.24	0.06
13.95	0.72	17.22	0.63	27.34	0.48	34.73	0.42	44.08	0.37	55.79	0.32	68.87	0.28	109.36	0.22	138.89	0.19	176.34	0.16	221.41	0.14	273.35	0.13	330.77	0.11	393.66	0.10
17.43	1.08	21.52	0.96	34.17	0.73	43.42	0.64	55.11	0.55	69.73	0.48	86.08	0.43	136.70	0.33	173.61	0.28	220.42	0.25	276.76	0.22	341.69	0.19	413.47	0.17	492.07	0.15
20.92	1.52	25.83	1.34	41.01	1.02	52.10	0.89	66.13	0.78	83.68	0.68	103.30	0.60	164.04	0.46	208.33	0.40	264.51	0.35	332.11	0.30	410.03	0.27	496.16	0.24	590.49	0.22
24.41	2.02	30.13	1.78	47.84	1.36	60.78	1.18	77.15	1.03	97.63	0.90	120.52	0.79	191.38	0.61	243.05	0.53	308.59	0.46	387.46	0.40	478.37	0.36	578.85	0.32	688.90	0.29
27.89	2.58	34.43	2.28	54.68	1.74	69.46	1.52	88.17	1.32	111.58	1.15	137.73	1.02	218.72	0.78	277.77	0.68	352.68	0.59	442.81	0.51	546.71	0.46	661.54	0.41	787.32	0.37
31.38	3.21	38.74	2.84	61.51	2.17	78.15	1.89	99.19	1.64	125.52	1.43	154.95	1.27	246.06	0.97	312.50	0.84	396.76	0.73	498.17	0.64	615.05	0.57	744.24	0.51	885.73	0.46
34.87	3.91	43.04	3.45	68.35	2.64	86.83	2.29	110.21	2.00	139.47	1.74	172.17	1.54	273.40	1.17	347.22	1.02	440.84	0.89	553.52	0.78	683.39	0.69	826.93	0.62	984.15	0.56
38.35	4.66	47.35	4.12	75.18	3.15	95.51	2.74	121.23	2.38	153.42	2.08	189.38	1.84	300.74	1.40	381.94	1.22	484.93	1.06	608.87	0.93	751.73	0.82	909.62	0.73	1082.56	0.66
41.84	5.48	51.65	4.84	82.02	3.70	104.20	3.22	132.25	2.80	167.36	2.44	206.60	2.16	328.08	1.65	416.66	1.43	529.01	1.25	664.22	1.09	820.06	0.96	992.32	0.86	1180.98	0.78
45.33	6.35	55.95	5.62	88.85	4.29	112.88	3.73	143.27	3.24	181.31	2.83	223.82	2.50	355.42	1.91	451.38	1.66	573.10	1.45	719.57	1.27	888.40	1.12	1075.01	1.00	1279.39	0.90
48.81	7.28	60.26	6.44	95.69	4.92	121.56	4.28	154.30	3.72	195.26	3.24	241.04	2.87	382.76	2.19	486.11	1.91	617.18	1.66	774.92	1.45	956.74	1.28	1157.70	1.15	1377.81	1.04
52.30	8.28	64.56	7.32	102.52	5.59	130.25	4.86	165.32	4.23	209.20	3.69	258.25	3.26	410.10	2.49	520.83	2.17	661.27	1.88	830.28	1.65	1025.08	1.46	1240.40	1.30	1476.22	1.18
55.79	9.33	68.87	8.25	109.36	6.30	138.93	5.48	176.34	4.77	223.15	4.15	275.47	3.67	437.44	2.81	555.55	2.44	705.35	2.12	885.63	1.86	1093.42	1.64	1323.09	1.47	1574.64	1.33
59.27	10.44	73.17	9.23	116.19	7.05	147.61	6.13	187.36	5.33	237.10	4.65	292.69	4.11	464.78	3.14	590.27	2.73	749.44	2.38	940.98	2.08	1161.76	1.84	1405.78	1.65	1673.05	1.49
62.76	11.60	77.48	10.26	123.03	7.83	156.30	6.81	198.38	5.93	251.04	5.17	309.90	4.57	492.11	3.49	624.99	3.03	793.52	2.64	996.33	2.31	1230.10	2.04	1488.48	1.83	1771.47	1.65
66.25	12.83	81.78	11.34	129.86	8.66	164.98	7.53	209.40	6.55	264.99	5.71	327.12	5.05	519.45	3.86	659.71	3.35	837.60	2.92	1051.68	2.56	1298.44	2.26	1571.17	2.02	1869.88	1.83
69.73	14.10	86.08	12.47	136.70	9.52	173.66	8.28	220.42	7.21	278.94	6.28	344.34	5.55	546.79	4.24	694.44	3.69	881.69	3.21	1107.03	2.81	1366.77	2.48	1653.86	2.22	1968.30	2.01
73.22	15.44	90.39	13.65	143.53	10.42	182.34	9.06	231.44	7.89	292.89	6.87	361.55	6.08	574.13	4.64	729.16	4.04	925.77	3.51	1162.39	3.08	1435.11	2.72	1736.56	2.43	2066.71	2.20
76.71	16.83	94.69	14.88	150.37	11.36	191.03	9.88	242.46	8.60	306.83	7.49	378.77	6.63	601.47	5.06	763.88	4.40	969.86	3.83	1217.74	3.35	1503.45	2.96	1819.25	2.65	2165.13	2.40
80.19	18.27	99.00	16.16	157.20	12.34	199.71	10.73	253.49	9.33	320.78	8.14	395.99	7.20	628.81	5.49	798.60	4.78	1013.94	4.16	1273.09	3.64	1571.79	3.22	1901.94	2.88	2263.54	2.60
83.68	19.77	103.30	17.48	164.04	13.35	208.39	11.61	264.51	10.10	334.73	8.80	413.20	7.79	656.15	5.94	833.32	5.17	1058.03	4.50	1328.44	3.94	1640.13	3.48	1984.63	3.12	2361.96	2.82
87.17	21.32	107.61	18.86	170.87	14.40	217.08	12.52	275.53	10.89	348.67	9.49	430.42	8.40	683.49	6.41	868.05	5.58	1102.11	4.85	1383.79	4.25	1708.47	3.76	2067.33	3.36	2460.37	3.04
90.66	22.93	111.91	20.28	177.71	15.48	225.76	13.46	286.55	11.71	362.62	10.21	447.64	9.03	710.83	6.89	902.77	6.00	1146.20	5.22	1439.15	4.57	1776.81	4.04	2150.02	3.61	2558.79	3.27
94.14	24.59	116.21	21.74	184.54	16.60	234.44	14.44	297.57	12.56	376.57	10.95	464.85	9.68	738.17	7.39	937.49	6.43	1190.28	5.59	1494.50	4.90	1845.15	4.33	2232.71	3.88	2657.20	3.50
97.63	26.30	120.52	23.26	191.38	17.76	243.13	15.44	308.59	13.44	390.51	11.71	482.07	10.36	765.51	7.91	972.21	6.88	1234.36	5.98	1549.85	5.24	1913.48	4.63	2315.41	4.15	2755.61	3.75
101.12	28.07	124.82	24.82	198.21	18.95	251.81	16.48	319.61	14.34	404.46	12.50	499.29	11.05	792.85	8.44	1006.93	7.34	1278.45	6.39	1605.20	5.59	1981.82	4.94	2398.10	4.42	2854.03	4.00
104.60	29.88	129.13	26.43	205.05	20.18	260.49	17.55	330.63	15.27	418.41	13.31	516.50	11.77	820.19	8.99	1041.65	7.82	1322.53	6.80	1660.55	5.95	2050.16	5.27	2480.79	4.71	2952.44	4.26
108.09	31.76	133.43	28.08	211.88	21.44	269.18	18.65	341.65	16.22	432.36	14.14	533.72	12.51	847.53	9.55	1076.38	8.31	1366.62	7.23	1715.90	6.33	2118.50	5.59	2563.49	5.01	3050.86	4.52
111.58	33.68	137.73	29.78	218.72	22.74	277.86	19.78	352.68	17.21	446.30	15.00	550.94	13.26	874.87	10.13	1111.10	8.81	1410.70	7.66	1771.26	6.71	2186.84	5.93	2646.18	5.31	3149.27	4.80
115.06	35.65	142.04	31.53	225.55	24.07	286.54	20.94	363.70	18.22	460.25	15.88	568.15	14.04	902.21	10.72	1145.82	9.33	1454.79	8.11	1826.61	7.10	2255.18	6.28	2728.87	5.62	3247.69	5.08
118.55	37.68	146.34	33.32	232.39	25.44	295.22	22.13	374.72	19.25	474.20	16.78	585.37	14.84	929.55	11.33	1180.54	9.86	1498.87	8.57	1881.96	7.51	2323.52	6.64	2811.57	5.94	3346.10	5.37
122.04	39.76	150.65	35.16	239.22	26.84	303.91	23.35	385.74	20.31	488.14	17.71	602.59	15.66	956.89	11.96	1215.26	10.40	1542.96	9.05	1937.31	7.92	2391.86	7.00	2894.26	6.27	3444.52	5.66
125.52	41.89	154.95	37.04	246.06	28.28	312.59	24.60	396.76	21.40	502.09	18.65	619.81	16.50	984.23	12.60	1249.99	10.96	1587.04	9.53	1992.66	8.35	2460.19	7.38	2976.95	6.60	3542.93	5.97
129.01	44.07	159.26	38.97	252.89	29.75	321.27	25.88	407.78	22.52	516.04	19.63	637.02	17.36	1011.57	13.25	1284.71	11.53	1631.12	10.03	2048.01	8.78	2528.53	7.76	3059.64	6.95	3641.35	6.28
132.50	46.30	163.56	40.94	259.73	31.26	329.96	27.19	418.80	23.66	529.98	20.62	654.24	18.23	1038.91	13.92	1319.43	12.11	1675.21	10.53	2103.37	9.22	2596.87	8.16	3142.34	7.30	3739.76	6.59
135.98	48.58	167.86	42.96	266.56	32.80	338.64	28.53	429.82	24.82	543.93	21.64	671.46	19.13	1066.25	14.61	1354.15	12.71	1719.29	11.05	2158.72	9.68	2665.21	8.56	3225.03	7.66	3838.18	6.92
139.47	50.91	172.17	45.03	273.40	34.38	347.32	29.90	440.84																			

Pressure loss tables

TOM® PVC-O 500 PN25

Pipe head loss is the energy of a hydraulic fluid that is lost along itself due to friction.

Below is the calculation of estimated water speeds depending on the selected pipe for installation.

Internal Diameter	DN90 PN25 83.0		DN110 PN25 100.8		DN125 PN25 114,5		DN140 PN25 128.3		DN160 PN25 146.6		DN200 PN25 183.3	
	Flow	J	Flow	J	Flow	J	Flow	J	Flow	J	Flow	J
	(m/s) l/s	m/km	(m/s) l/s	m/km	(m/s) l/s	m/km	(m/s) l/s	m/km	(m/s) l/s	m/km	(m/s) l/s	m/km
0.1	0.54	0.16	0.80	0.13	1.03	0.11	1.29	0.10	1.69	0.08	2.64	0.06
0.2	1.08	0.59	1.60	0.47	2.06	0.40	2.59	0.35	3.38	0.30	5.28	0.23
0.3	1.62	1.24	2.39	0.99	3.09	0.86	3.88	0.75	5.06	0.64	7.92	0.49
0.4	2.16	2.12	3.19	1.69	4.12	1.46	5.17	1.28	6.75	1.09	10.56	0.84
0.5	2.71	3.22	3.99	2.56	5.15	2.21	6.46	1.93	8.44	1.65	13.19	1.27
0.6	3.25	4.51	4.79	3.59	6.18	3.09	7.76	2.71	10.13	2.32	15.83	1.78
0.7	3.79	5.99	5.59	4.78	7.21	4.11	9.05	3.60	11.82	3.08	18.47	2.37
0.8	4.33	7.67	6.38	6.10	8.24	5.27	10.34	4.61	13.50	3.94	21.11	3.04
0.9	4.87	9.53	7.18	7.59	9.27	6.55	11.64	5.74	15.19	4.91	23.75	3.78
1.0	5.41	11.58	7.98	9.24	10.30	7.96	12.93	6.97	16.88	5.97	26.39	4.60
1.1	5.95	13.82	8.78	11.02	11.33	9.50	14.22	8.31	18.57	7.12	29.03	5.48
1.2	6.49	16.23	9.58	12.96	12.36	11.16	15.51	9.76	20.26	8.37	31.67	6.44
1.3	7.03	18.82	10.37	15.00	13.39	12.95	16.81	11.33	21.94	9.70	34.31	7.47
1.4	7.57	21.58	11.17	17.22	14.42	14.85	18.10	13.00	23.63	11.12	36.94	8.57
1.5	8.12	24.57	11.97	19.57	15.45	16.88	19.39	14.77	25.32	12.64	39.58	9.74
1.6	8.66	27.69	12.77	22.06	16.47	19.00	20.69	16.65	27.01	14.25	42.22	10.98
1.7	9.20	30.97	13.57	24.69	17.50	21.26	21.98	18.62	28.70	15.94	44.86	12.28
1.8	9.74	34.42	14.36	27.42	18.53	23.63	23.27	20.70	30.38	17.71	47.50	13.65
1.9	10.28	38.04	15.16	30.31	19.56	26.12	24.56	22.87	32.07	19.58	50.14	15.09
2.0	10.82	41.82	15.96	33.34	20.59	28.73	25.86	25.17	33.76	21.54	52.78	16.59
2.1	11.36	45.77	16.76	36.50	21.62	31.44	27.15	27.54	35.45	23.58	55.42	18.16
2.2	11.90	49.88	17.56	39.79	22.65	34.27	28.44	30.01	37.13	25.69	58.05	19.79
2.3	12.44	54.15	18.35	43.17	23.68	37.22	29.74	32.60	38.82	27.89	60.69	21.49
2.4	12.99	58.67	19.15	46.72	24.71	40.27	31.03	35.27	40.51	30.18	63.33	23.26
2.5	13.53	63.26	19.95	50.40	25.74	43.43	32.32	38.04	42.20	32.56	65.97	25.08
2.6	14.07	68.02	20.75	54.21	26.77	46.71	33.61	40.89	43.89	35.01	68.61	26.97
2.7	14.61	72.93	21.55	58.14	27.80	50.09	34.91	43.87	45.57	37.54	71.25	28.93
2.8	15.15	78.00	22.34	62.15	28.83	53.58	36.20	46.92	47.26	40.16	73.89	30.94
2.9	15.69	83.23	23.14	66.34	29.86	57.18	37.49	50.07	48.95	42.86	76.53	33.02
3.0	16.23	88.61	23.94	70.65	30.89	60.89	38.79	53.33	50.64	45.64	79.17	35.16
3.1	16.77	94.15	24.74	75.08	31.92	64.70	40.08	56.66	52.33	48.50	81.80	37.36
3.2	17.31	99.84	25.54	79.64	32.95	68.62	41.37	60.08	54.01	51.42	84.44	39.62
3.3	17.86	105.80	26.33	84.26	33.98	72.64	42.66	63.60	55.70	54.44	87.08	41.95
3.4	18.40	111.80	27.13	89.07	35.01	76.78	43.96	67.23	57.39	57.54	89.72	44.33
3.5	18.94	117.95	27.93	93.99	36.04	81.01	45.25	70.93	59.08	60.71	92.36	46.78
3.6	19.48	124.25	28.73	99.04	37.07	85.35	46.54	74.72	60.77	63.97	95.00	49.28
3.7	20.02	130.71	29.53	104.21	38.10	89.79	47.83	78.61	62.45	67.28	97.64	51.85
3.8	20.56	137.31	30.32	109.43	39.13	94.34	49.13	82.61	64.14	70.69	100.28	54.48
3.9	21.10	144.07	31.12	114.83	40.16	98.99	50.42	86.67	65.83	74.18	102.92	57.16
4.0	21.64	150.97	31.92	120.36	41.19	103.75	51.71	90.82	67.52	77.75	105.55	59.90

Pressure loss tables

TOM® PVC-O 500 PN25

Pipe head loss is the energy of a hydraulic fluid that is lost along itself due to friction.

Below is the calculation of estimated water speeds depending on the selected pipe for installation.

DN225 PN25 206.2		DN250 PN25 229.1		DN315 PN25 288.6		DN355 PN25 325.3		DN400 PN25 366.5		DN450 PN25 412.3		DN500 PN25 458.1		DN630 PN25 577,2		DN710 PN25 654.7		DN800 PN25 733.0		DN900 PN25 824.1		DN1000 PN25 915.6		DN1100 PN25 1007.2		DN1200 PN25 1098.8	
Flow	J	Flow	J	Flow	J	Flow	J	Flow	J	Flow	J	Flow	J	Flow	J	Flow	J	Flow	J	Flow	J	Flow	J	Flow	J	Flow	J
l/s	m/km	l/s	m/km	l/s	m/km	l/s	m/km	l/s	m/km	l/s	m/km	l/s	m/km	l/s	m/km	l/s	m/km	l/s	m/km	l/s	m/km	l/s	m/km	l/s	m/km	l/s	m/km
3.34	0.06	4.12	0.05	6.54	0.04	8.31	0.03	10.55	0.03	13.35	0.03	16.48	0.02	26.17	0.02	33.66	0.01	42.20	0.01	53.34	0.01	65.84	0.01	79.67	0.01	94.83	0.01
6.68	0.20	8.24	0.18	13.08	0.14	16.62	0.12	21.10	0.10	26.70	0.09	32.96	0.08	52.33	0.06	67.33	0.05	84.40	0.05	106.68	0.04	131.68	0.04	159.35	0.03	189.65	0.03
10.02	0.43	12.37	0.38	19.62	0.29	24.93	0.25	31.65	0.22	40.05	0.19	49.45	0.17	78.50	0.13	100.99	0.11	126.60	0.10	160.02	0.09	197.53	0.08	239.02	0.07	284.48	0.06
13.36	0.73	16.49	0.65	26.17	0.50	33.24	0.43	42.20	0.38	53.40	0.33	65.93	0.29	104.67	0.22	134.66	0.19	168.79	0.17	213.36	0.15	263.37	0.13	318.70	0.12	379.30	0.10
16.70	1.11	20.61	0.98	32.71	0.75	41.56	0.65	52.75	0.57	66.76	0.49	82.41	0.44	130.83	0.33	168.32	0.29	210.99	0.25	266.70	0.22	329.21	0.19	398.37	0.17	474.13	0.16
20.04	1.56	24.73	1.38	39.25	1.05	49.87	0.91	63.30	0.80	80.11	0.69	98.89	0.61	157.00	0.47	201.99	0.40	253.19	0.35	320.04	0.31	395.05	0.27	478.05	0.24	568.96	0.22
23.38	2.07	28.86	1.83	45.79	1.40	58.18	1.22	73.85	1.06	93.46	0.92	115.37	0.82	183.16	0.62	235.65	0.54	295.39	0.47	373.38	0.41	460.89	0.36	557.72	0.33	663.78	0.29
26.72	2.65	32.98	2.34	52.33	1.79	66.49	1.56	84.40	1.35	106.81	1.18	131.86	1.04	209.33	0.80	269.32	0.69	337.59	0.60	426.72	0.53	526.73	0.47	637.40	0.42	758.61	0.38
30.05	3.30	37.10	2.91	58.87	2.23	74.80	1.94	94.95	1.68	120.16	1.47	148.34	1.30	235.50	0.99	302.98	0.86	379.79	0.75	480.06	0.65	592.58	0.58	717.07	0.52	853.43	0.47
33.39	4.01	41.22	3.54	65.42	2.71	83.11	2.35	105.50	2.05	133.51	1.78	164.82	1.58	261.66	1.21	336.65	1.04	421.99	0.91	533.40	0.80	658.42	0.70	796.75	0.63	948.26	0.57
36.73	4.78	45.35	4.23	71.96	3.23	91.42	2.81	116.05	2.44	146.86	2.13	181.30	1.88	287.83	1.44	370.31	1.24	464.18	1.09	586.74	0.95	724.26	0.84	876.42	0.75	1043.09	0.68
40.07	5.61	49.47	4.97	78.50	3.79	99.73	3.30	126.60	2.87	160.21	2.50	197.78	2.21	314.00	1.69	403.98	1.46	506.38	1.28	640.08	1.11	790.10	0.99	956.10	0.88	1137.91	0.80
43.41	6.51	53.59	5.76	85.04	4.40	108.04	3.83	137.15	3.33	173.56	2.90	214.27	2.57	340.16	1.96	437.64	1.69	548.58	1.48	693.41	1.29	855.94	1.14	1035.77	1.02	1232.74	0.92
46.75	7.47	57.71	6.61	91.58	5.05	116.36	4.39	147.70	3.82	186.92	3.33	230.75	2.94	366.33	2.25	471.31	1.94	590.78	1.70	746.75	1.48	921.78	1.31	1115.45	1.17	1327.56	1.06
50.09	8.49	61.83	7.51	98.12	5.73	124.67	4.99	158.24	4.34	200.27	3.78	247.23	3.34	392.49	2.55	504.97	2.20	632.98	1.93	800.09	1.69	987.63	1.49	1195.12	1.33	1422.39	1.20
53.43	9.57	65.96	8.46	104.67	6.46	132.98	5.62	168.79	4.89	213.62	4.26	263.71	3.77	418.66	2.88	538.63	2.48	675.18	2.18	853.43	1.90	1053.47	1.68	1274.80	1.50	1517.22	1.36
56.77	10.70	70.08	9.47	111.21	7.23	141.29	6.29	179.34	5.47	226.97	4.77	280.19	4.22	444.83	3.22	572.30	2.78	717.38	2.44	906.77	2.13	1119.31	1.88	1354.47	1.68	1612.04	1.52
60.11	11.90	74.20	10.52	117.75	8.04	149.60	6.99	189.89	6.08	240.32	5.30	296.68	4.69	470.99	3.58	605.96	3.09	759.57	2.71	960.11	2.36	1185.15	2.09	1434.15	1.87	1706.87	1.69
63.45	13.15	78.32	11.63	124.29	8.88	157.91	7.73	200.44	6.72	253.67	5.86	313.16	5.18	497.16	3.96	639.63	3.42	801.77	2.99	1013.45	2.61	1250.99	2.31	1513.82	2.07	1801.69	1.87
66.79	14.46	82.45	12.79	130.83	9.77	166.22	8.50	210.99	7.39	267.02	6.44	329.64	5.70	523.33	4.35	673.29	3.76	843.97	3.29	1066.79	2.87	1316.84	2.54	1593.50	2.27	1896.52	2.05
70.13	15.83	86.57	14.00	137.37	10.69	174.53	9.30	221.54	8.09	280.37	7.05	346.12	6.24	549.49	4.76	706.96	4.11	886.17	3.60	1120.13	3.14	1382.68	2.78	1673.17	2.49	1991.34	2.25
73.47	17.26	90.69	15.26	143.91	11.65	182.84	10.14	232.09	8.82	293.72	7.69	362.60	6.80	575.66	5.19	740.62	4.48	928.37	3.93	1173.47	3.43	1448.52	3.03	1752.85	2.71	2086.17	2.45
76.81	18.74	94.81	16.57	150.46	12.66	191.16	11.01	242.64	9.58	307.07	8.35	379.09	7.38	601.83	5.64	774.29	4.87	970.57	4.26	1226.81	3.72	1514.36	3.29	1832.52	2.94	2181.00	2.66
80.15	20.27	98.94	17.93	157.00	13.69	199.47	11.91	253.19	10.36	320.43	9.03	395.57	7.99	627.99	6.10	807.95	5.26	1012.77	4.61	1280.15	4.02	1580.20	3.56	1912.20	3.18	2275.82	2.88
83.48	21.86	103.06	19.34	163.54	14.77	207.78	12.84	263.74	11.17	333.78	9.74	412.05	8.61	654.16	6.58	841.62	5.68	1054.96	4.98	1333.49	4.34	1646.04	3.84	1991.87	3.43	2370.65	3.10
86.82	23.51	107.18	20.79	170.08	15.88	216.09	13.81	274.29	12.02	347.13	10.47	428.53	9.26	680.32	7.07	875.28	6.11	1097.16	5.35	1386.83	4.67	1711.89	4.13	2071.55	3.69	2465.47	3.34
90.16	25.21	111.30	22.30	176.62	17.03	224.40	14.81	284.84	12.89	360.48	11.23	445.01	9.93	706.49	7.58	908.95	6.55	1139.36	5.74	1440.17	5.01	1777.73	4.43	2151.22	3.96	2560.30	3.58
93.50	26.97	115.42	23.85	183.16	18.22	232.71	15.84	295.39	13.78	373.83	12.01	461.50	10.63	732.66	8.11	942.61	7.00	1181.56	6.14	1493.51	5.35	1843.57	4.74	2230.90	4.24	2655.13	3.83
96.84	28.78	119.55	25.45	189.71	19.44	241.02	16.91	305.94	14.71	387.18	12.82	477.98	11.34	758.82	8.66	976.28	7.47	1223.76	6.55	1546.85	5.71	1909.41	5.05	2310.57	4.52	2749.95	4.08
100.18	30.65	123.67	27.10	196.25	20.70	249.33	18.00	316.49	15.66	400.53	13.65	494.46	12.07	784.99	9.22	1009.94	7.96	1265.96	6.98	1600.19	6.08	1975.25	5.38	2390.25	4.81	2844.78	4.35
103.52	32.56	127.79	28.80	202.79	22.00	257.64	19.13	327.04	16.64	413.88	14.51	510.94	12.83	811.16	9.80	1043.61	8.46	1308.16	7.41	1653.53	6.47	2041.09	5.72	2469.92	5.12	2939.60	4.62
106.86	34.54	131.91	30.54	209.33	23.33	265.95	20.29	337.59	17.65	427.23	15.39	527.42	13.61	837.32	10.39	1077.27	8.97	1350.35	7.86	1706.87	6.86	2106.94	6.06	2549.60	5.43	3034.43	4.90
110.20	36.56	136.04	32.34	215.87	24.70	274.27	21.48	348.14	18.69	440.59	16.29	543.91	14.40	863.49	11.00	1110.93	9.49	1392.55	8.32	1760.21	7.26	2172.78	6.42	2629.27	5.74	3129.26	5.19
113.54	38.64	140.16	34.17	222.41	26.10	282.58	22.70	358.69	19.75	453.94	17.21	560.39	15.22	889.65	11.62	1144.60	10.03	1434.75	8.80	1813.55	7.67	2238.62	6.78	2708.95	6.07	3224.08	5.48
116.88	40.77	144.28	36.06	228.96	27.54	290.89	23.95	369.24	20.84	467.29	18.16	576.87	16.06	915.82	12.27	1178.26	10.59	1476.95	9.28	1866.89	8.09	2304.46	7.16	2788.62	6.40	3318.91	5.79
120.22	42.96	148.40	37.99	235.50	29.02	299.20	25.23	379.79	21.95	480.64	19.14	593.35	16.92	941.99	12.92	1211.93	11.16	1519.15	9.78	1920.23	8.53	2370.30	7.54	2868.30	6.75	3413.73	6.10
123.56	45.19	152.53	39.97	242.04	30.53	307.51	26.55	390.34	23.10	493.99	20.13	609.83	17.80	968.15	13.59	1245.59	11.74	1561.35	10.29	1973.56	8.97	2436.15	7.93	2947.97	7.10	3508.56	6.41
126.90	47.48	156.65	41.99	248.58	32.07	315.82	27.89	400.89	24.27	507.34	21.15	626.32	18.70	994.32	14.28	1279.26	12.33	1603.55	10.81	2026.90	9.43	2501.99	8.34	3027.64	7.46	3603.39	6.74
130.24	49.82	160.77	44.06	255.12	33.65	324.13	29.26	411.44	25.46	520.69	22.19	642.80	19.63	1020.49	14.99	1312.92	12.94	1645.74	11.34	2080.24	9.89	2567.83	8.75	3107.32	7.83	3698.21	7.07
133.58	52.21	164.89	46.17	261.66	35.27	332.44	30.67	421.99	26.69																		

Pressure loss tables

Quick, low-priced installation

🕒 **TOM® PVC-O pipes are less than half PVC and HDPE pipes weight:** between six and twelve times less per linear metre than ductile iron pipes of the same nominal external diameter. Due to their lightness, **they can be lifted without mechanical assistance** (cranes, hoists, etc), up to a diameter of DN315 mm, which brings down the overall cost of installation.

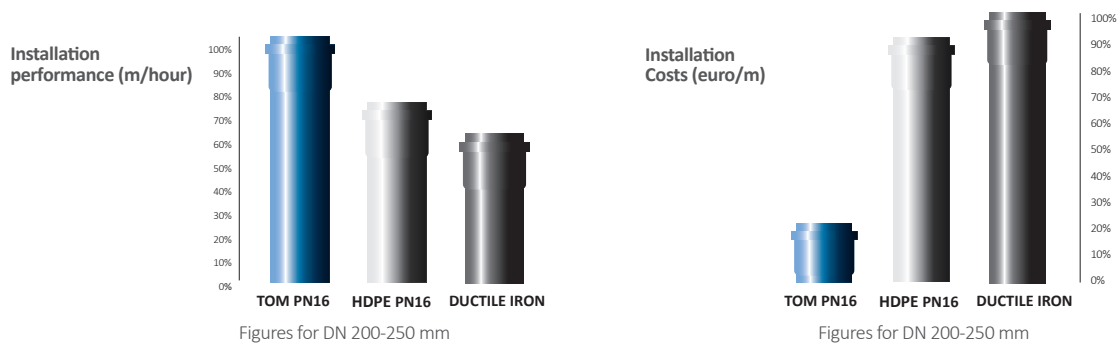
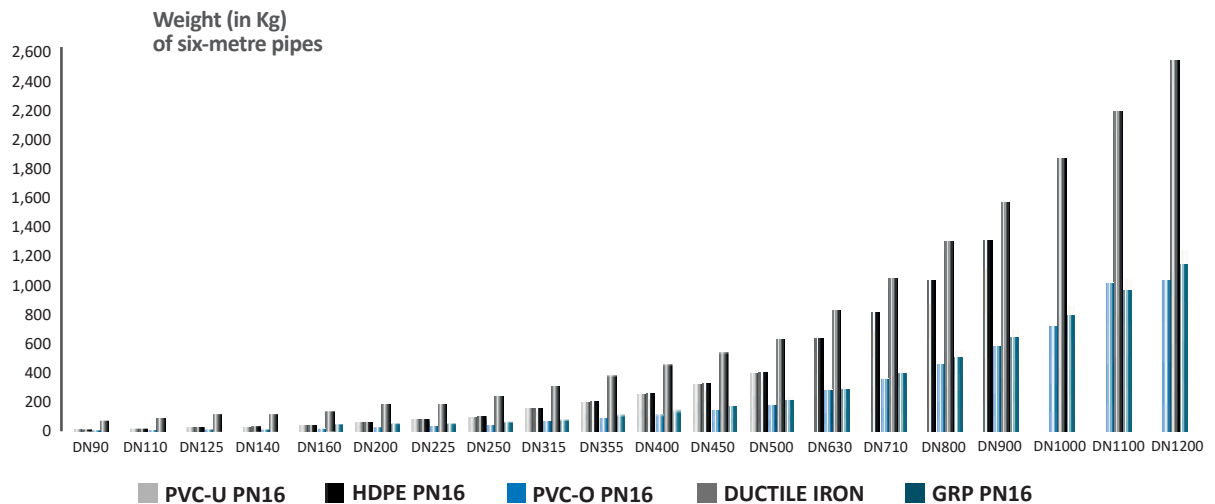

Because TOM® pipes have a high resistance, they offer considerable **advantages in terms of unloading, installation in trenches and pipe-to-pipe connection**. Moreover, these pipes are so easy to connect to one another that they offer very high performance: they can be handled and installed by lower-qualified workers and without machinery (up to DN315 mm).

For all these reasons **TOM® pipes offer huge advantages in terms of installation in metres/installation-hours** compared to other solutions.

Transport and Storage

🕒 TOM® pipes characteristics make them easy to transport and store, which means considerable savings in costs.

To optimize transport, it is advisable to stick to the following guidelines:

- If different diameters are going to be transported in the same batch, the biggest diameters must be placed below.
- Leave the sockets free, alternating sockets and free ends.

Water Hammer

To calculate possible excess pressures (P) produced by water hammers, the celerity (α) must be first determined. It is a characteristic of the pipe and the fluid that it transports, and it evaluates the change in the water speed (V) which can occur in the valve openings and closings or for startups or shutdowns of the pump.

$$P = \frac{a \cdot V}{g} ; a = \frac{9900}{\sqrt{48.3 + K_c \cdot \frac{D_m}{e}}} ; K_c = \frac{10^{10}}{E}$$

TOM® PN16 (230 PSI) PIPES

V	a	P (water hammer)	
		m	bar
0.5	293	15	1.5
1.0	293	30	3.0
1.5	293	45	4.5
2.0	293	60	6.0
2.5	293	75	7.5
3.0	293	90	9.0
3.5	293	105	10.5
4.0	293	119	11.9

K9 DUCTILE IRON PIPES

V	a	P (water hammer)	
		m	bar
0.5	1100	56	5.6
1.0	1100	112	11.2
1.5	1100	168	16.8
2.0	1100	224	22.4
2.5	1100	280	28.0
3.0	1100	336	33.6
3.5	1100	392	39.2
4.0	1100	449	44.9

Air locks in the pipes during filling can be highly damaging when water hammers arise and can cause excess pressure far beyond the levels established in the tables above. Thus it is important to follow the following recommendations:

- **Filling the pipe** should only be carried out at low speed (approximately 0.05 m/s) and at the lowest point in the pipe system.
- **When installing purging mechanisms** (double effect suction mechanisms) at the highest points on each section of pipe.
- During filling it is important to leave opened the elements capable of **evacuating air** (valves), and close them from bottom to top in the pipe as the pipe fills up with water.

Reduction ratios: Temperature and Application

High temperatures (over 25 °C) or demanding or aggressive applications can reduce Allowable Operating Pressure (PFA) of pipes in comparison to the Nominal Pressure (NP).

$$PFA = PN \cdot f_T \cdot f_A$$

The derating factor (f_T) as function of operating temperature can be obtained from the graph on the right.

The derating factor related to application of the system (f_A) must be determined by the Project Manager.

Temperature Ratio Graph

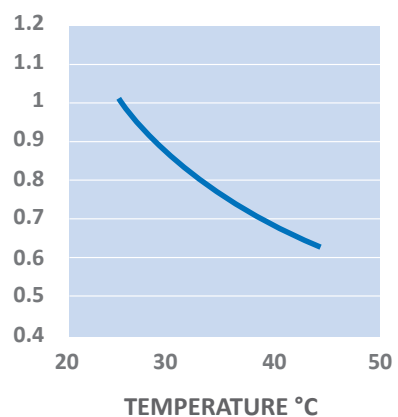

Note: Project design and execution is responsibility of the Project Manager and the Contractor, respectively.

DN (mm)	Maximum angular deviation Angle (°)	Displacement between sockets D (mm) ⁽¹⁾
90-1200	2°	200

(1) Pipes not exceeding 6.00 metres in length.



Anchoring

⊙ Pipes that are subjected to internal hydrostatic pressure are also subjected to thrust forces at every point of change of direction (angular deviation of the pipe, elbows, curves, etc) and in parts and components that increase or reduce the pipe's cross-section, such as valves, branches, overflows, etc. These forces can be extremely strong and are even capable of moving the ground, causing pipes to displace. In general terms, the thrust forces can be gauged using the following formula:

$$\text{Force(kg)} = k \cdot \text{Pressure (bar)} \cdot \text{Pipe Cross Section (cm}^2\text{)}$$

In caps and tees at 90°: $K=1$

In reducers: $k=1 - \frac{\text{Smallest cross-section}}{\text{Biggest cross-section}}$

In changes of direction: $k=2 \cdot \sin \frac{\beta}{2}$

It is important to ensure that the concrete is poured directly into the previously positioned ground and that it has the required mechanical resistance. When designing the anchoring, bear in mind that **the joints must be left free** to enable its subsequent inspection during hydraulic trials.

◀ Anchoring at points of change of direction

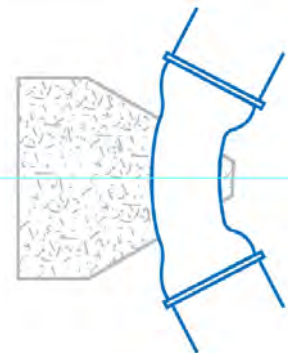

Bedding and Filling the Trench

⊙ To analyze the optimal and most efficient way for the preparation of bedding on which to settle the pipe and the subsequent filling and compacting the ground on the sides and top of the pipe, see our installation instructions or contact with our technical and commercial service.

Trials and Entry into Service

⊙ **The EN 805 Water Supply Standard in vigor** is applicable to all aspects of on-site trials and Entry into Service. During installation, it is important to carry out trials on the lengths of completely laid pipeline (the length can vary between 500 and 1,000 metres). The ends of each length of pipeline will be sealed off using the appropriate components, and the pipeline must be partly filled with the joints in full view.

The trial pressure (STP) in N/mm^2 ($0.1 \text{ N/mm}^2 = 1 \text{ atm}$) will be as follows:

a) If the water hammer has been calculated precisely: $\text{STP} = \text{MDP} + 0.1$

b) If the water hammer is estimated, use the lesser of the following two values:

$$\text{STP} = \text{MDP} + 0.5 \quad \text{and} \quad \text{STP} = 1.5 \cdot \text{MDP}$$

MDP is the Maximum Design Pressure, i.e. the maximum allowable pressure in a pipe, including the effect of a water hammer. The Entry into Service of piping for drinking water must comply with the required health standards for water for human consumption.

To avoid damaging pipes in storage, it is advisable to:

- Store the pipes horizontally on a flat surface, on supports spaced 1.5 metres apart, to keep the pipes from bowing.
- Do not stack higher than 1.5 metres.
- Leave the sockets free, alternating sockets and free ends.
- If the pipes are stored in direct sunlight, cover the pallets with opaque material and with ventilation to prevent overheating. Light colors of the protective material, which reflect solar radiation are preferable because they prevent overheating of the pipes.

Excavation

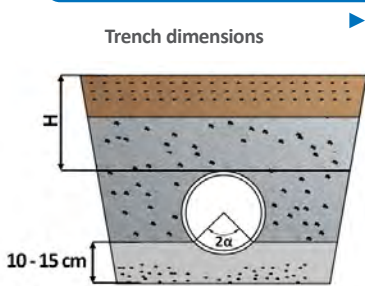

- Although other types of applications are possible, **TOM® pipes are particularly recommended for underground installation.** The dimensions of the trench will depend on the loads to which pipes will be submitted (road traffic, soil types, etc). As a rule of thumb the pipes' crown will be at a minimum depth of 1 metre (100 cm); if this is not applicable check your project at www.tomcalculation to find the recommended depth.

The **minimum width of the trench** can be calculated using the following tables:

DN (mm)	Minimum width of trench B (m)
90-250	0.60
315	0.85
355	1.10
400	1.10
450	1.15
500	1.20
630	1.35

DN (mm)	Minimum width of trench B (m)
710	1.60
800	1.65
900	1.75
1000	1.85
1100	1.95
1200	2.05

Depth of trench H (m)	Minimum width of trench B (m)
H < 1.00	0.60
1.00 < H < 1.75	0.80
1.75 < H < 4.00	0.90
H > 4.00	1.00

The **bottom of the trench** should be homogeneous, uniform and ensure a solid support along the entire length of the pipe.

Assembly

- Checks must be made to **ensure that joints are clean** both inside the pipe and outside.
- To facilitate assembly, it is advisable to **lubricate the sockets and free ends using lubricating soap.**
- **Align the pipe-ends** and slot the sockets into place.
- **Pipes can be slotted into one another** using levers (use only materials that will not damage the pipes, e.g. wood), or slings. However, with small diameters, due to the elastic coupling system and the lightness of the pipe, a short, sharp movement of the hand is enough to join the pipes.

Angular Deviation

- Angular deviations in the union system are allowed. This means that the piping can be channeled following a desired line.



Certificates

TOM® SIRIM QAS International
Product Certification Licence
according to **ISO 16422**



TOM® SIRIM QAS International
Eco-Label Licence according to
SIRIM ECO 054



TOM® SPAN Water according to
SPAN/BPI/300-10/774/A/W-2

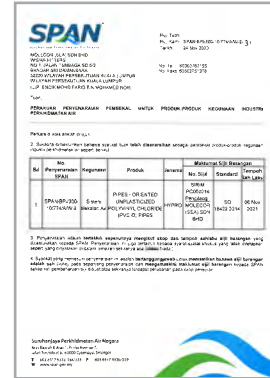

TOM® AENOR Product certification
according to **UNE-EN 17176**



TOM® AENOR Product certification
according to **ISO 16422**



TOM® Certification of Approval of
The State Water Authority of Sarawak

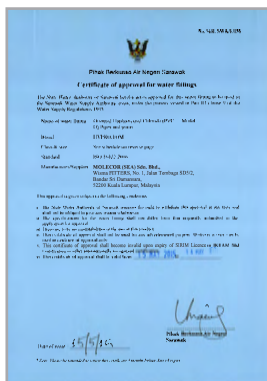

TOM® Certification of Approval of
The Jabatan Air Negeri Sabah



TOM® UKAS Certificate of Approval
according to **ISO 9001**



Latest certificates can be downloaded at www.molecor.com

Certificates

TOM® My Hijau mark Green Label
 Certification according to
ISO 14024 Type I Eco-Label



ecoFITTM® My Hijau mark Green Label
 Certification according to
ISO 14024 Type I Eco-Label

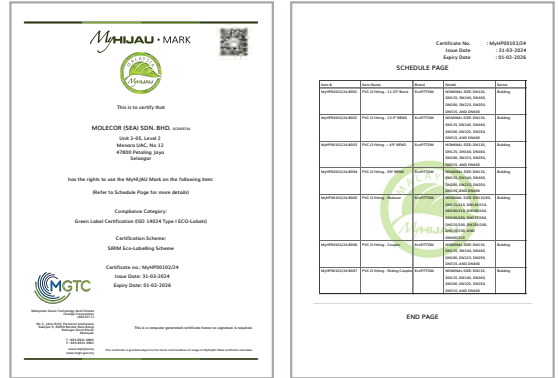

ecoFITTM® AENOR Product certification
 according to **UNE-CEN/TS 17176-3**



ecoFITTM® SIRIM International Product
 Certification Licence according to
CEN/TS 17176-3, number PC011357



ecoFITTM® Certificate of Approval of
 The State Water Authority of Sarawak.

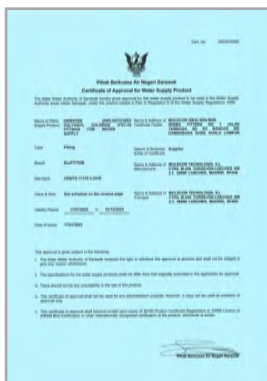

Operation Clean Sweep®
 (OCS) certificate

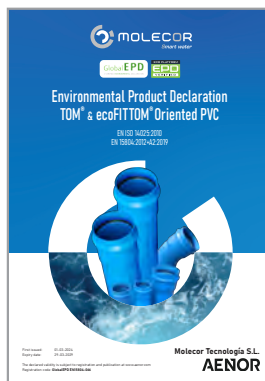

Operation Clean Sweep®
 (OCS) certificate



Latest certificates can be downloaded at www.molecorsea.com



MOLECOR

South East Asia



Experience



Quality



Differentiated and innovative products



Range



Technical and commercial support



Logistics service

TOM

MOLECOR (SEA) Head Office
 Unit 2-05, Level 2, Menara UAC, No 12, Jalan PJU 7/5, Mutiara Damansara,
 47800 Petaling Jaya, Selangor Darul Ehsan, Malaysia
 T + 603 6420 6291 | F + 603 6420 6291

MOLECOR (SEA) Plant
 No 10, Jalan Gebeng 2/13, Kawasan Perindustrian Gebeng,
 26080 Kuantan, Pahang Darul Makmur, Malaysia
 T + 609.583.4920 | F + 609.583.4926



TOM ^{ECO}FITTON TR5

inquiry.malaysia@molecor.com

www.molecorsea.com